

Particle Physics at the Energy Frontier

Kevin Stenson

University of Colorado – Boulder

November 7, 2007

What we know (we think)

- 3 families of spin $\frac{1}{2}$ quarks & leptons make up matter
- 3 types of interactions with spin 1 force carriers
 - Electromagnetism (QED) carried by massless photons; felt by charged particles
 - Massive (80-90 GeV) W and Z mediate weak force; felt by quarks & leptons
 - Strong force (QCD) carried by massless gluons; felt by quarks

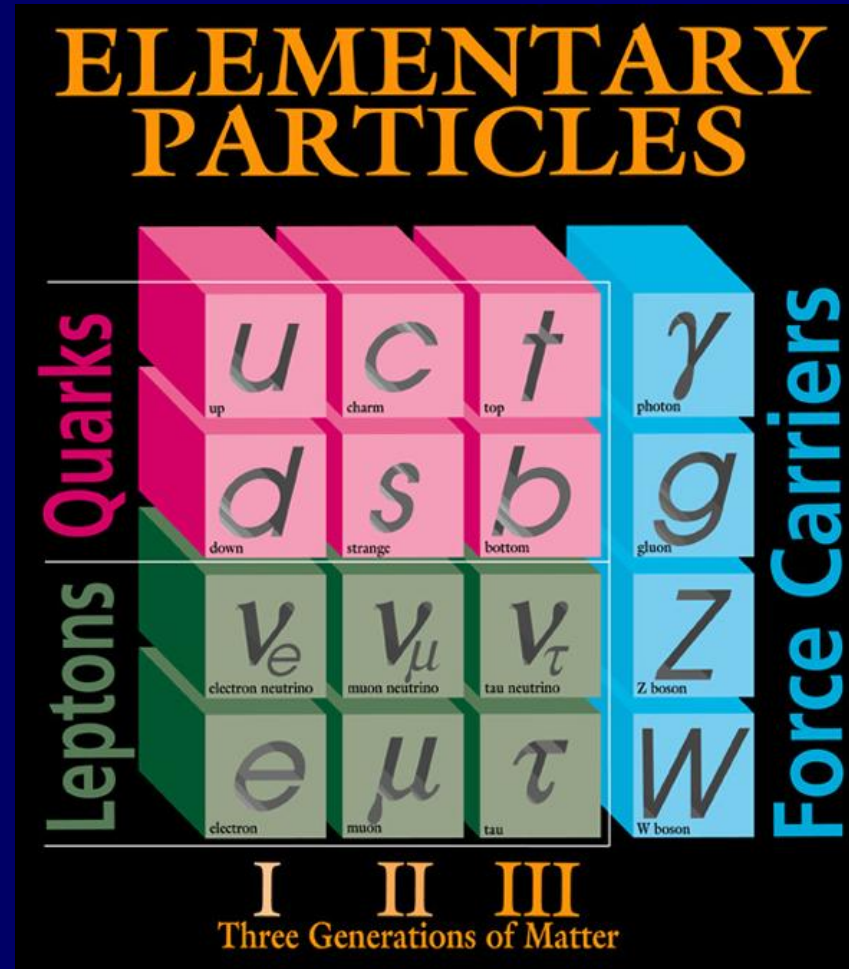

Electroweak theory

- Can combine electromagnetism and weak forces into electroweak theory
- Precision measurements generally find very good agreement between data and theory



How to get electroweak theory

- At low energy we see E&M and weak forces
- These are unified at high energy (>1 TeV)
- The weak force contains massive force vector bosons (W^+, W^-, Z^0) but adding mass terms for W & Z to the theory does not work
- Use spontaneous symmetry breaking – the Higgs mechanism
- The Higgs mechanism solves two problems:
 - Mechanism to give W and Z bosons a mass in such a way as to avoid unitarity violation of WW (or ZZ) cross section at high energy
 - Also gives mass to quarks and charged leptons

Spontaneous Symmetry Breaking (SSB)

Solutions which do not respect a symmetry of the Lagrangian

Example 1: Ferromagnetism

- Above T_C spins are disordered – rotational symmetry
- Below T_C spins align creating spontaneous magnetization along a preferred direction – breaking rotational symmetry

Example 2: A stick?

- An ideal stick has a force compressing its length
- Below a critical force the ideal stick remains intact with cylindrical symmetry
- Above a critical force the stick bows in a particular direction violating the cylindrical symmetry

The Higgs Mechanism

- Complex vacuum scalar field Φ with potential $V(\Phi) = \mu^2|\Phi|^2 + \lambda|\Phi|^4$
- For $\mu^2 < 0$, minimum at non-zero energy gives vacuum expectation value (v.e.v.): $|\Phi|^2 = -\mu^2/2\lambda$
- This spontaneous symmetry breaking separates electroweak into E&M and weak and gives W and Z mass
- Higgs field permeates vacuum and the coupling strength to the Higgs determines the elementary particle mass
- The Higgs field also contributes to the vacuum energy density

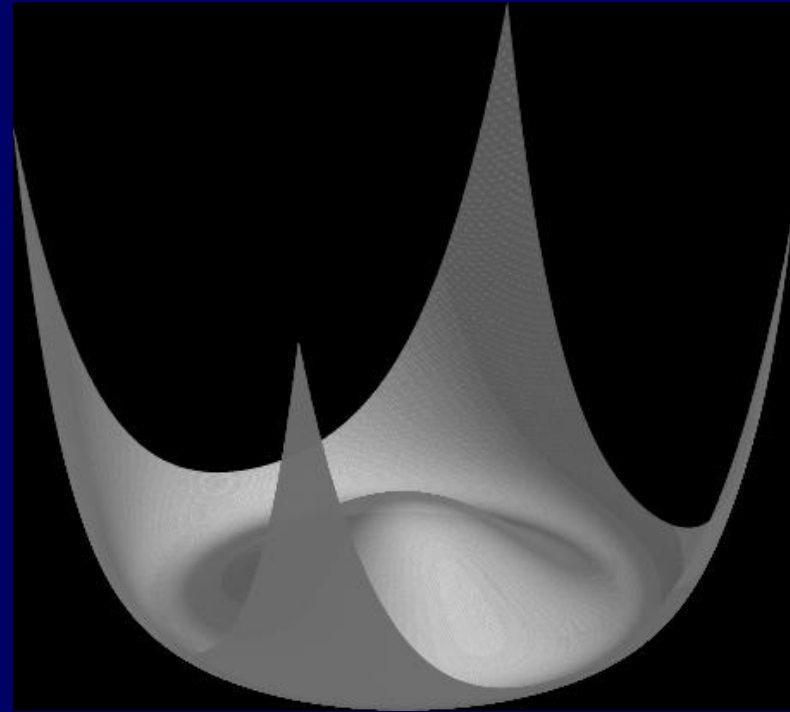

Higgs status

- Direct searches at 200 GeV e^+e^- collider LEP ruled out a mass less than 114 GeV
- Higgs mass affects other aspects of theory
- Thus, experimental measurements can be combined with theory to constrain the Higgs mass
- Expect $M_H < 184$ GeV at 95% CL

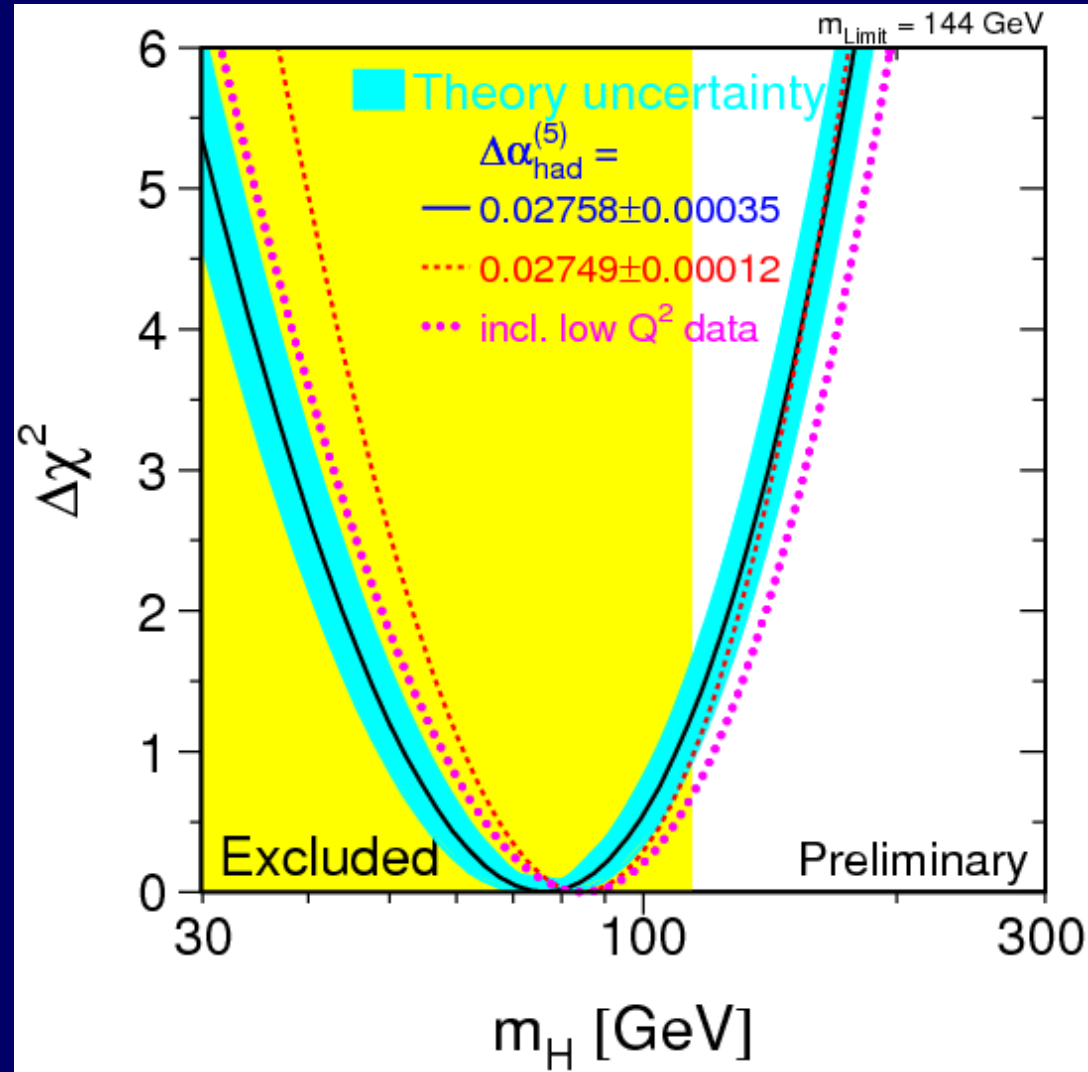

Grand Unified Theories (GUT)

- Standard Model does not really explain anything
- So we speculate about a high energy über theory unifying electroweak & strong forces
- Coupling strengths come together around 10^{15} GeV
- Also need to quantize gravity at $M_{\text{Planck}} = 10^{19}$ GeV
- GUT unifies matter and leads to proton decay
- Spontaneous symmetry breaking of the GUT gives the observed theories

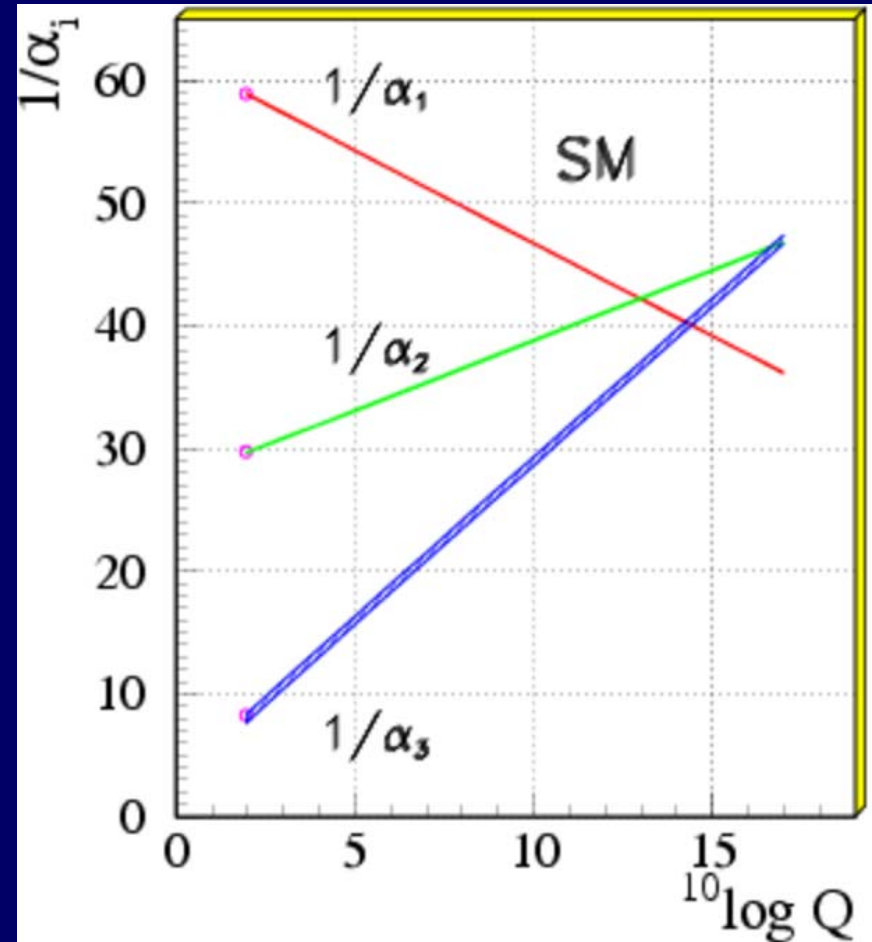

The Hierarchy Problem

- Assume new physics at high mass ($M \gg 100 \text{ GeV}$) which could be GUT and/or quantum gravity
- Particles couple to Higgs giving mass corrections proportional to M (could be $M_{\text{GUT}} \sim 10^{15} \text{ GeV}$)
- To keep Higgs mass $\sim 100 \text{ GeV}$ requires unnatural fine tuning (1 part in 10^{13} for GUT)
- Need new physics at lower energy ($< 1 \text{ TeV}$) to stop this
- Not just any new physics will do
- The prohibitive favorite is supersymmetry (SUSY)

Supersymmetry

- Every elementary particle has a supersymmetric partner: bosons \rightarrow fermions & fermions \rightarrow bosons
 - Cool names: squark, sbottom, slepton, selectron, stau, zino, gluino, photino, wino, bino, neutralino, higgsino
- At high energy, supersymmetry holds, so regular particles and their sparticles have the same mass
- Unknown spontaneous symmetry breaking splits the masses with sparticles having higher mass
- Solves hierarchy problem – contributions from particle loops canceled by sparticle loops
- MSSM = Minimal Supersymmetric Standard Model

SUSY may be more GUT friendly

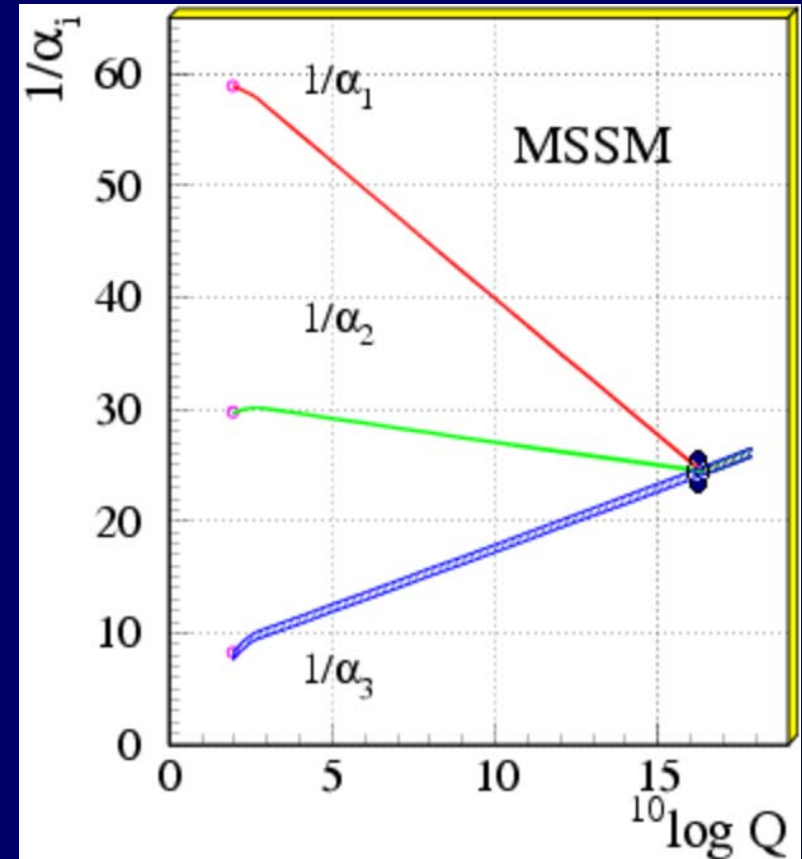
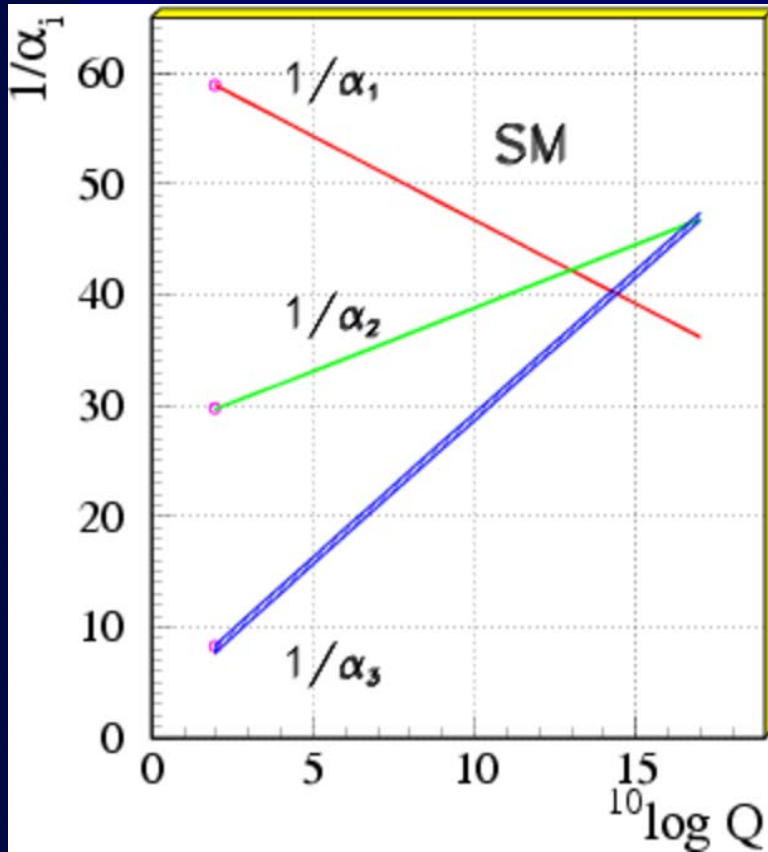

Adding contributions from supersymmetry, the coupling constants appear to unify at 10^{16} GeV

What's the universe made of, anyway?

Galaxy rotation curves & cluster motion, cosmic microwave background, distant supernovae, big-bang nucleosynthesis, inflation, and simulations of structure formation give a consistent picture

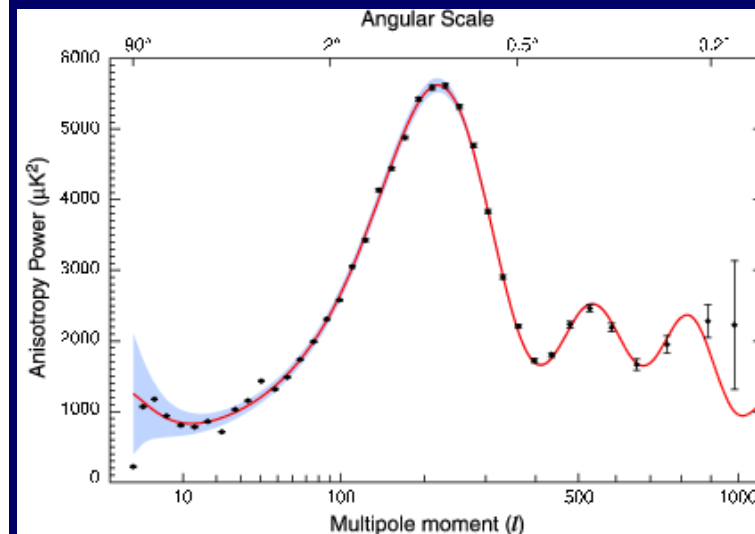
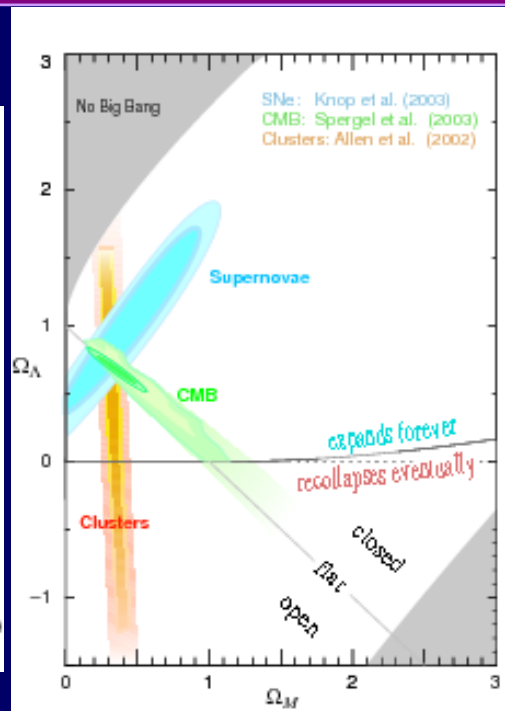
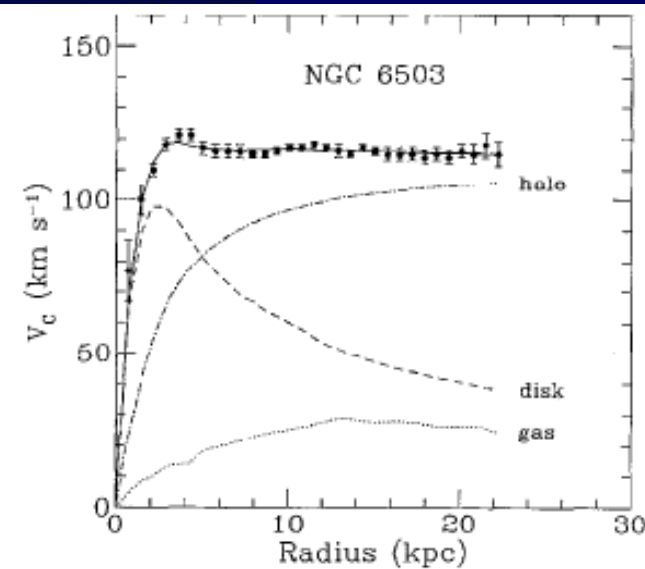

SUSY for Dark Matter?

A weakly interacting massive particle (WIMP) at a mass between 0.1-1 TeV has an annihilation cross section which causes freeze out to occur at the time necessary to give the amount of dark matter observed

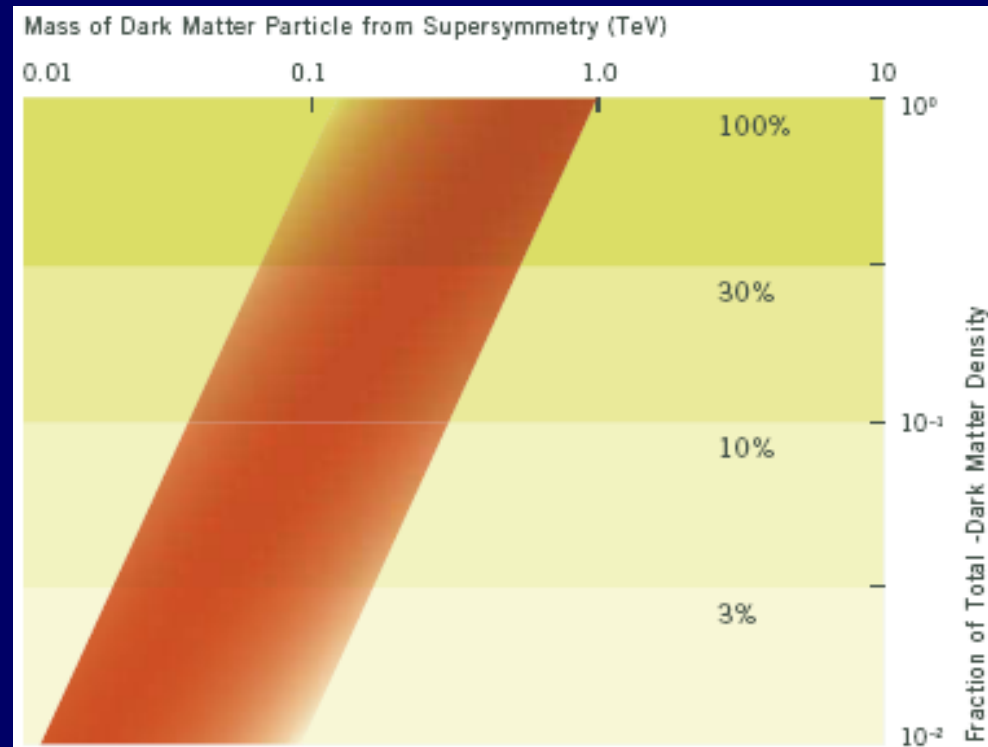
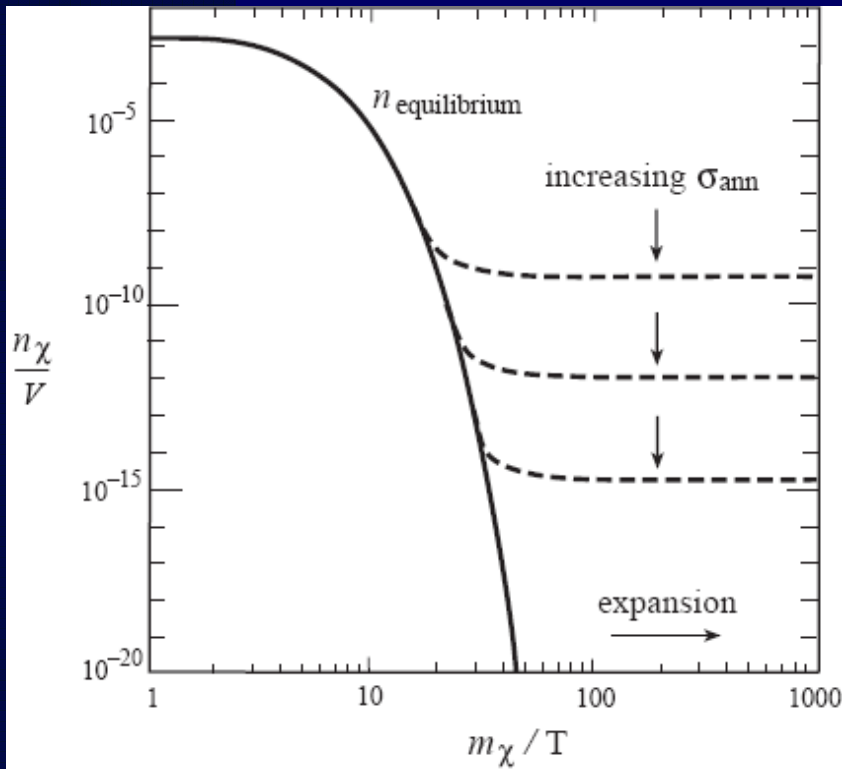

SUSY details

The Good

- Solves hierarchy problem – stable Higgs mass
- May provide cold dark matter candidate
- Provides better unification of coupling constants
- May be quantum gravity theory friendly

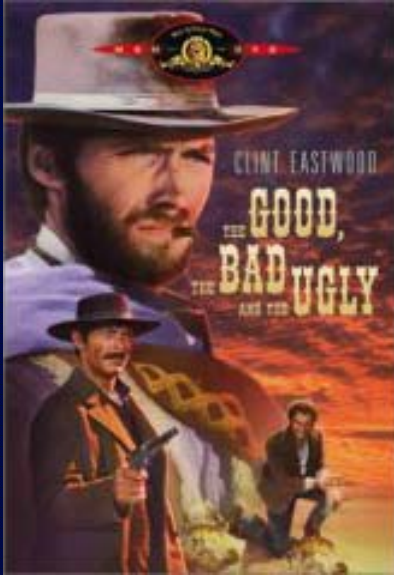

- Source of symmetry breaking (SSB) unknown
- Generic SSB model has > 100 free parameters

The Bad

The Copout?

mSugra = MSSM Supergravity assumes SSB is gravity mediated around GUT scale which reduces the free parameters to 5

How do we find all this stuff?

- Need a high energy accelerator to produce the interesting particles
- Need detectors to record what happens when the particles decay
- Need to separate the interesting stuff from the background

Energy frontier colliders

High enough energy to produce the particles of interest

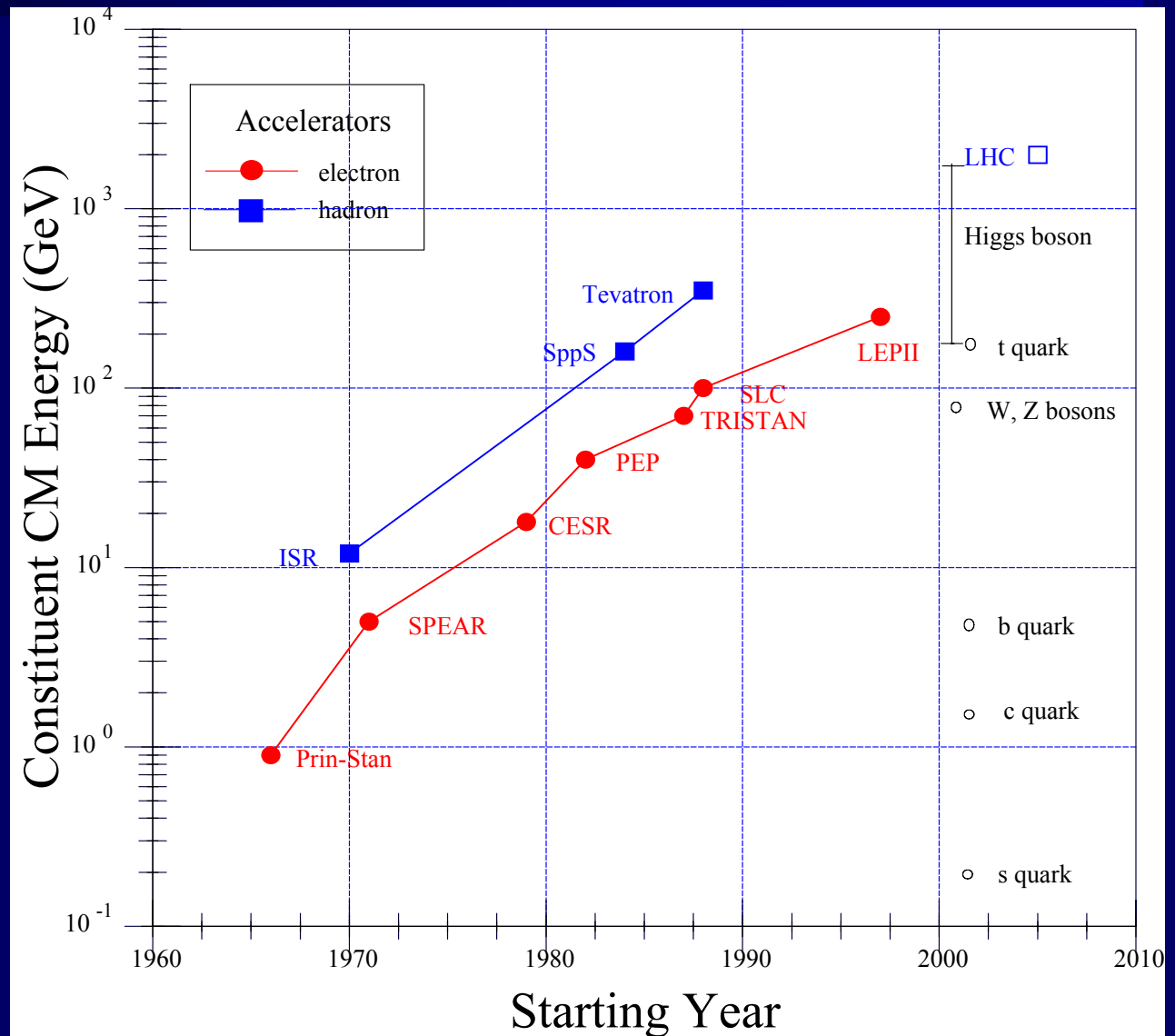

LHC at CERN



11/7/07

Particle Physics at the Energy Frontier

17

Overall view of the LHC experiments.

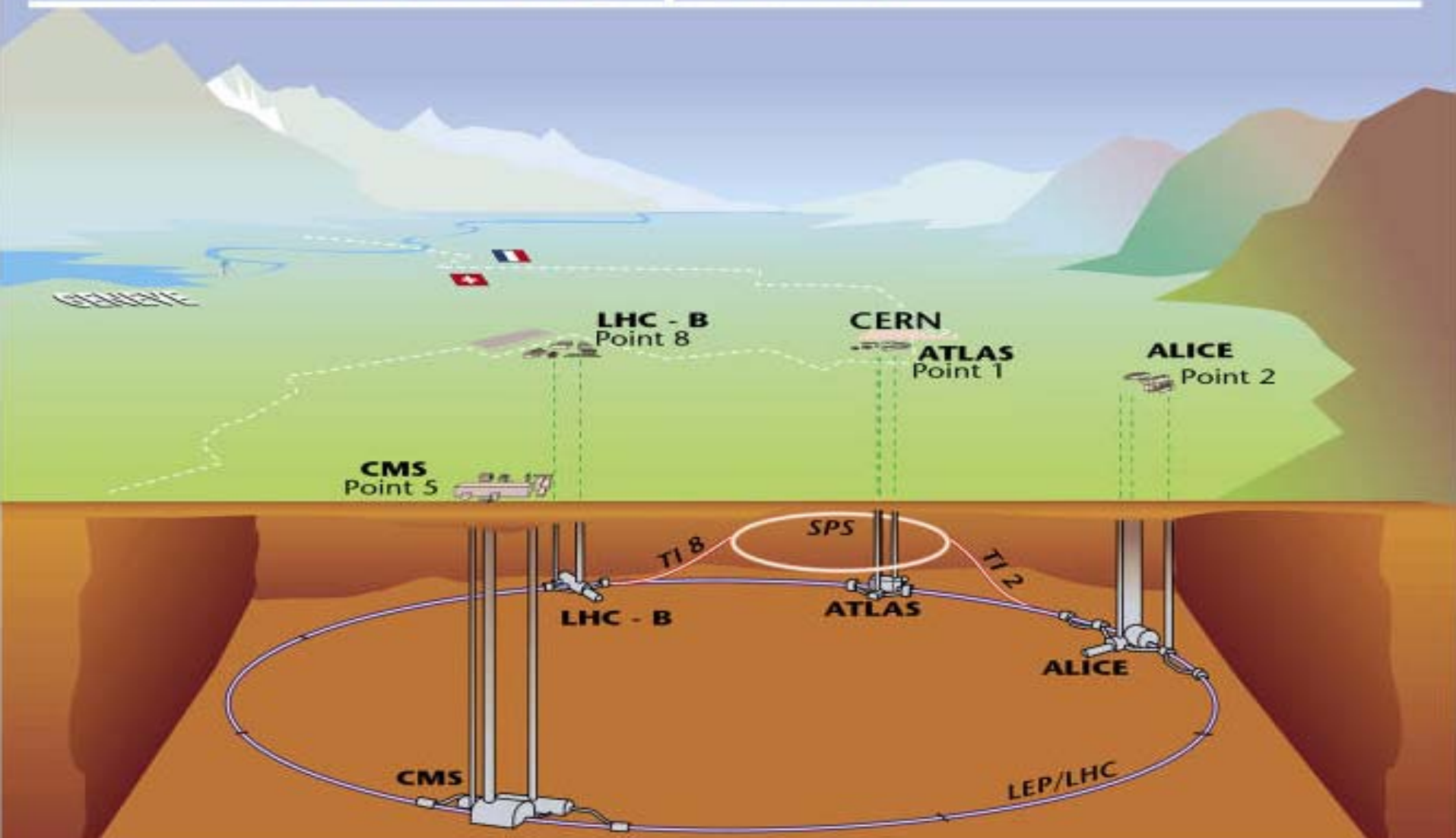

E540 - V10/09/97

LHC Collisions

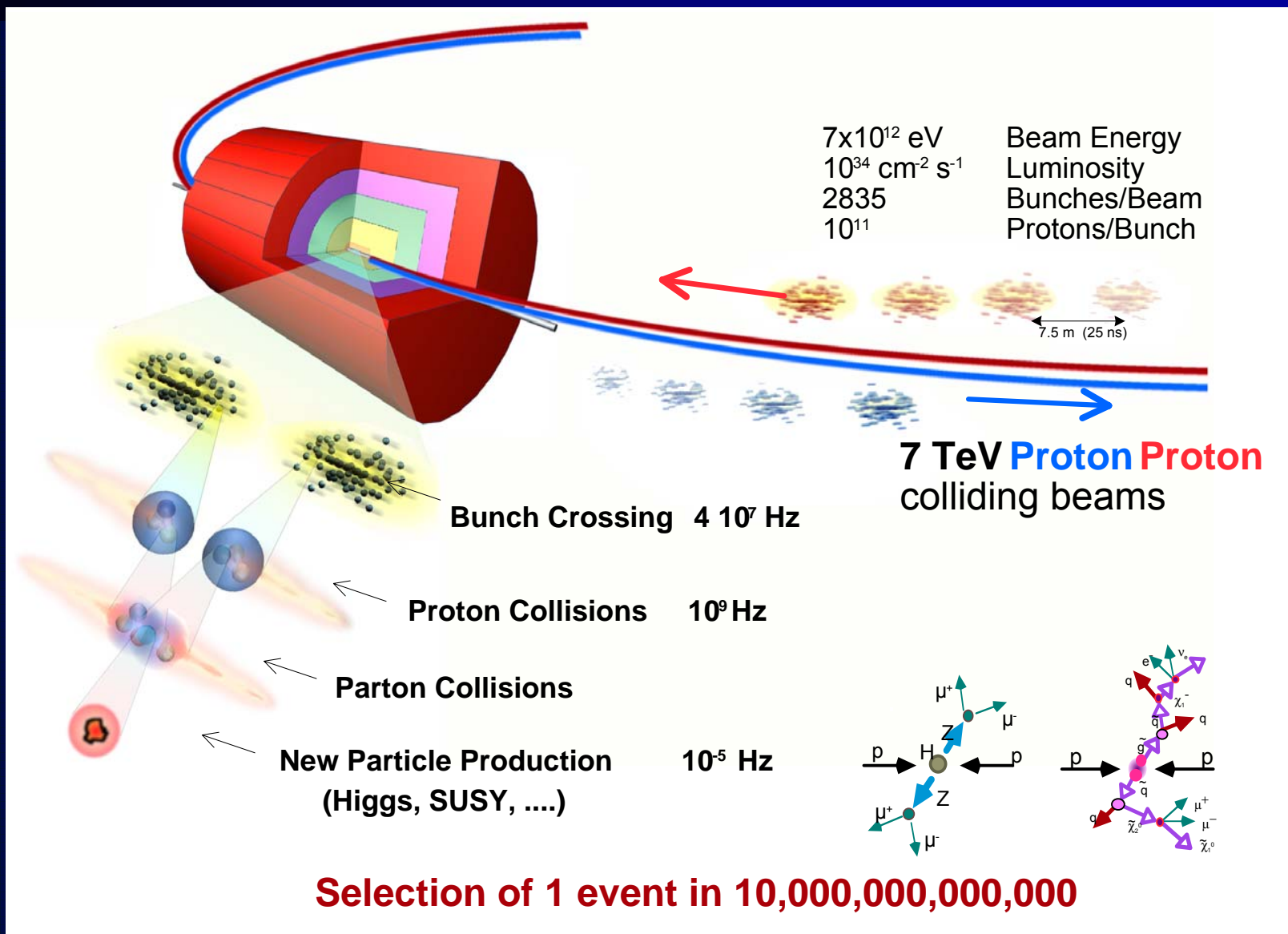

LHC Statistics

- 27 km circumference
- Up to 100 m underground
- Two 0.5 A proton beams at 7 TeV
- Stored energy in each beam is 350 MJ
- 8.3 tesla magnets steer beam
- Beams are bunched; bunch spacing is 25 ns
- 20 minimum bias events per beam crossing
- Thousands of particles produced per beam crossing

LHC Detectors to record the events

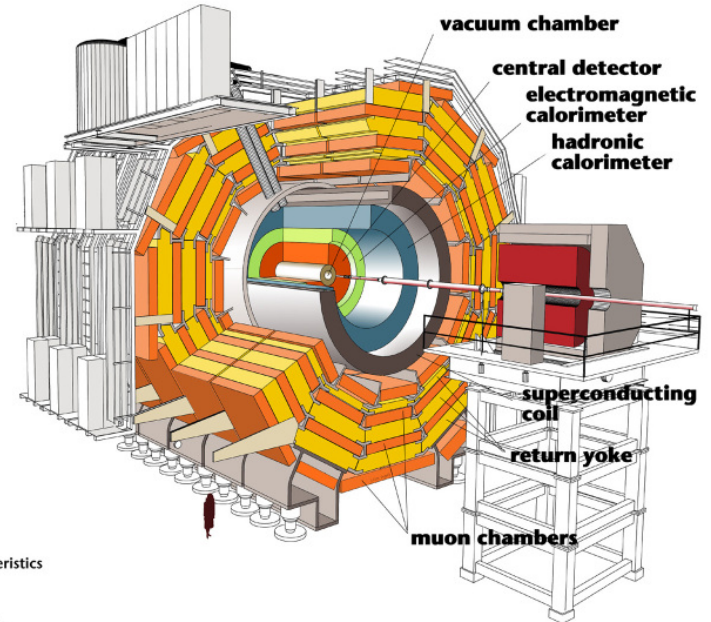
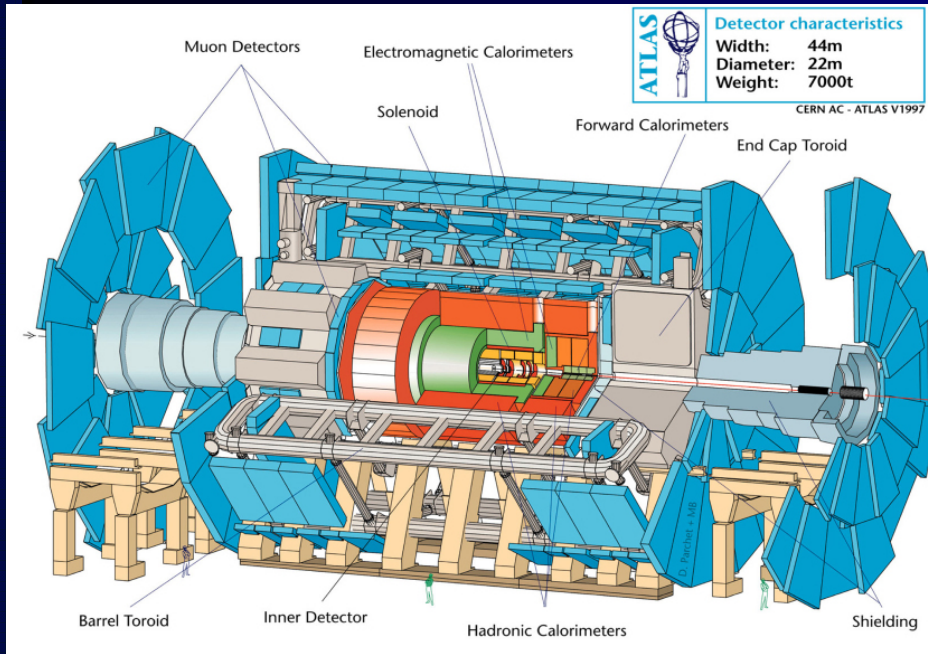



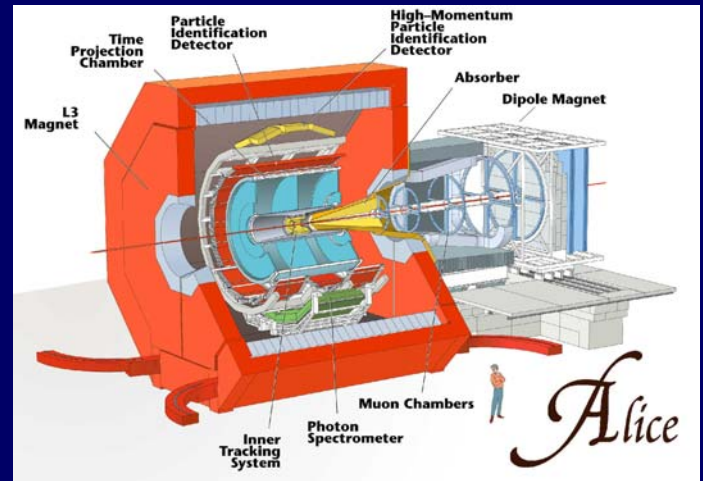
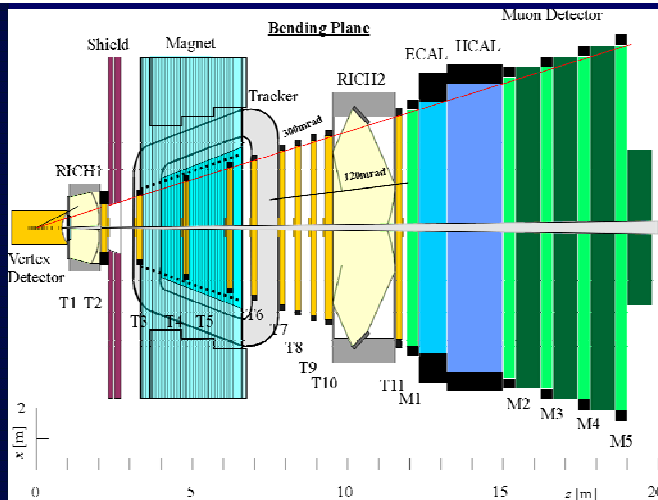



Detector characteristics
 Width: 22m
 Diameter: 15m
 Weight: 14'500t



Reconstructing an event

- Need handles to separate signal from background
- Start by identifying and measuring (p or E) particles
 - Photons (γ) in ECAL
 - Electrons in tracker and ECAL
 - Muons make it to muon system
 - Jets in tracker, ECAL, and HCAL
 - Neutrinos, black holes, a stable lightest supersymmetric particle (LSP), and possibly other particles leave no trace, resulting in missing Et

type	tracking	ECAL	HCAL	MUON
γ				
e				
μ				
Jet				
Et miss				

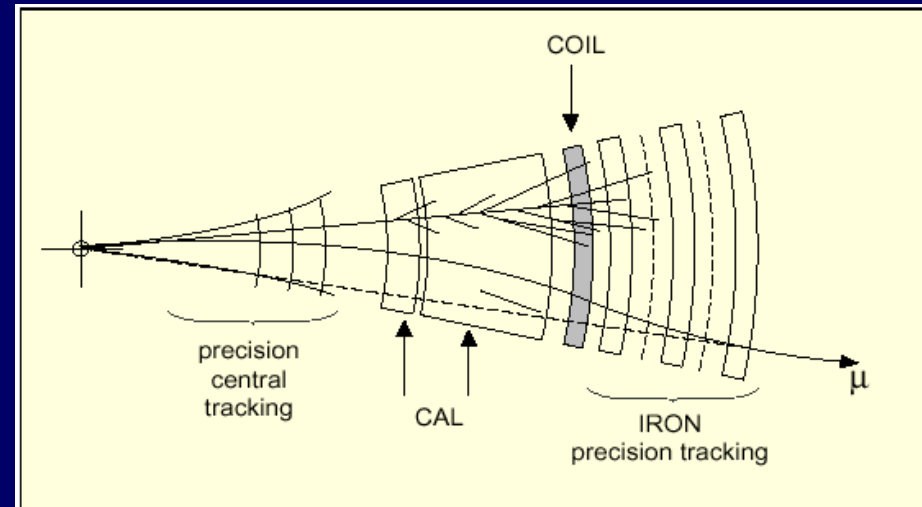

CMS Slice

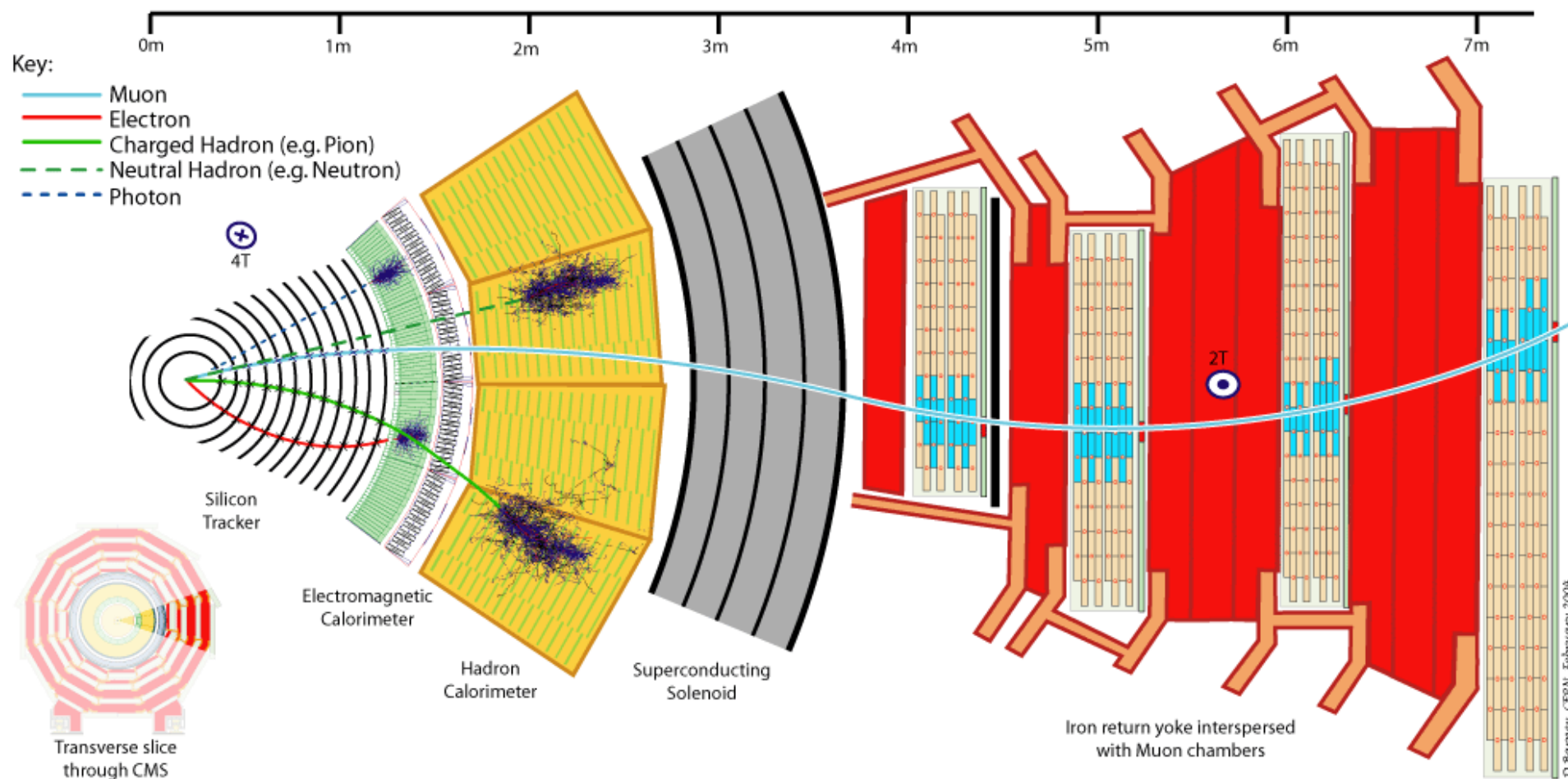

Tracking

- Charged particles ionize atoms
- Electrons (and/or holes) drift due to applied electric field and are collected in a segmented detector
- Using many layers and an applied magnetic field, charged particles are tracked and their momentum is measured
- Vertices can be formed from tracks to discriminate against boring interactions or identify b/τ jets

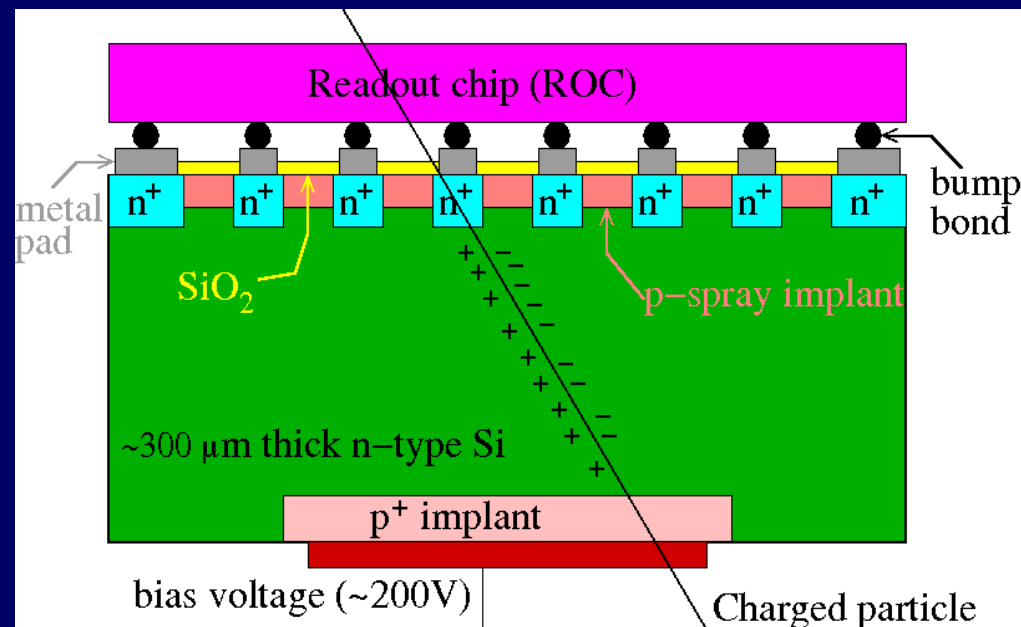

CMS Tracker

- All silicon tracker: 3 layers of $100 \times 150 \mu\text{m}^2$ pixels plus ~ 10 layers of silicon strips with $\sim 100 \mu\text{m}$ pitch
- Entire system at -10°C which improves radiation tolerance by a factor of 100 compared to 25°C
- Double sided strip detectors have a stereo view

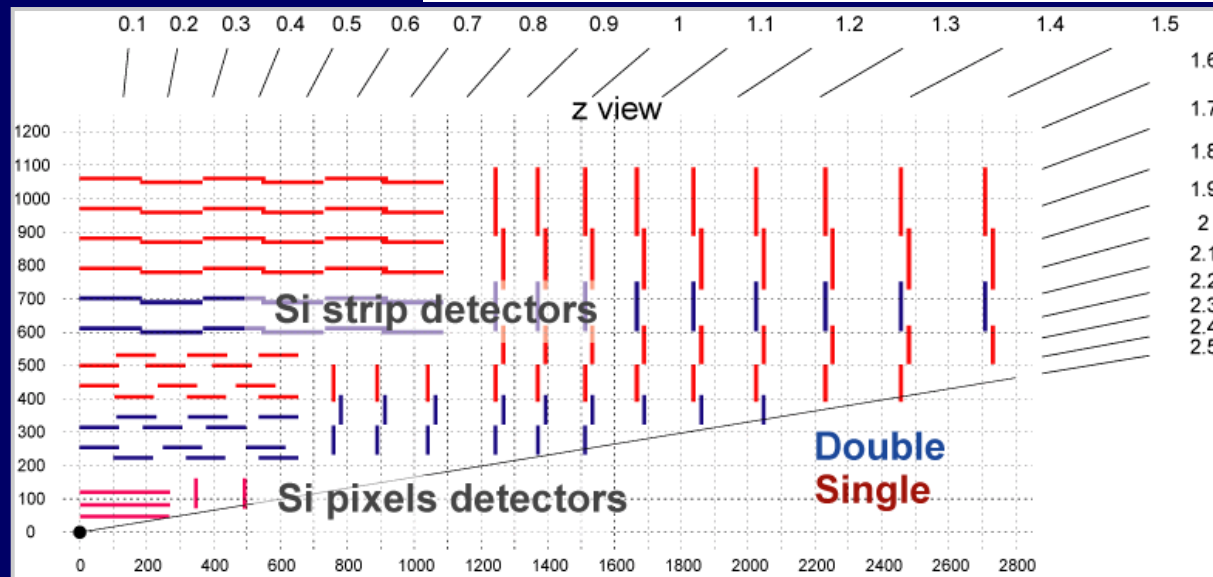
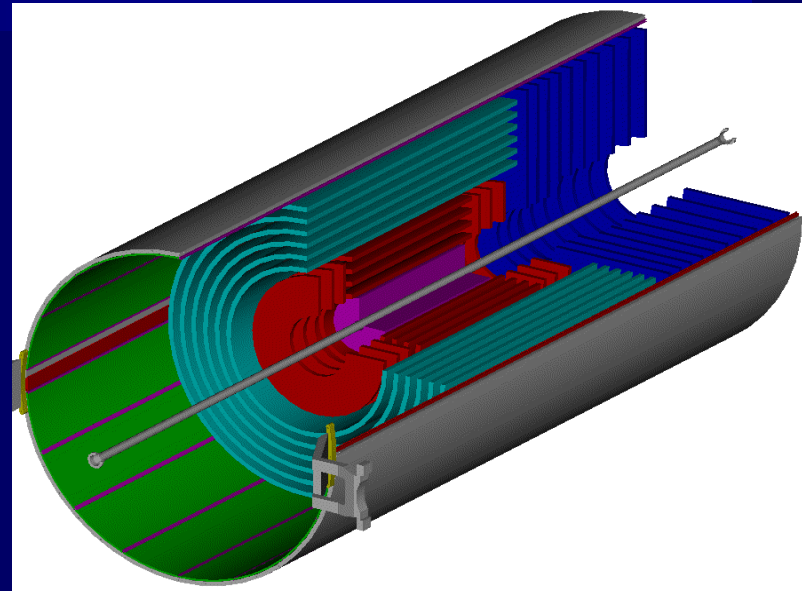

CMS Pixels

- Barrel and forward pixel systems
- Individual construction and insertion
- 48 million barrel pixels in 3 rings
- 18 million forward pixels in 2+2 disks

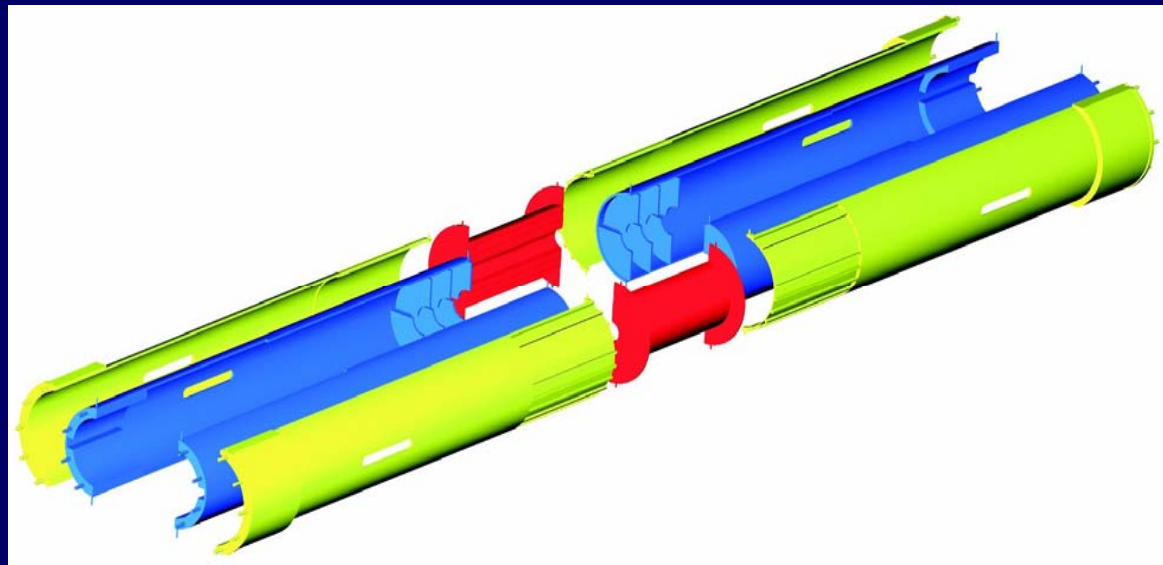
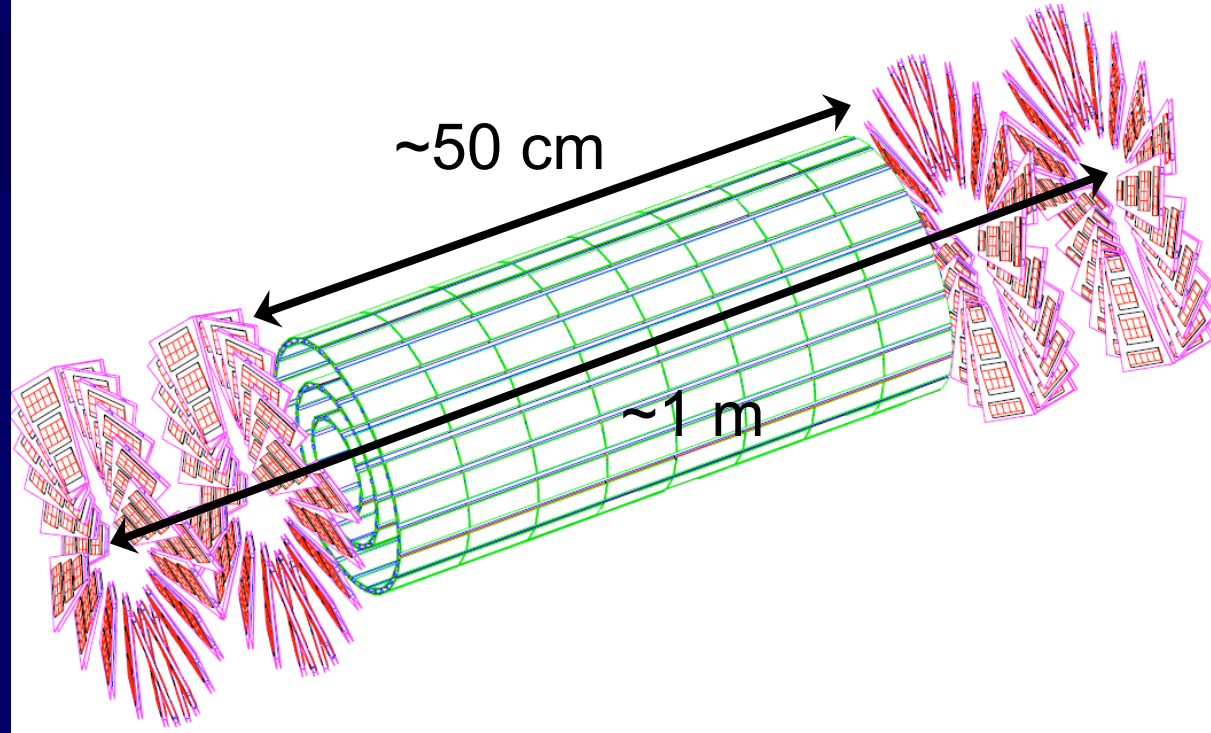

CMS Barrel Pixels

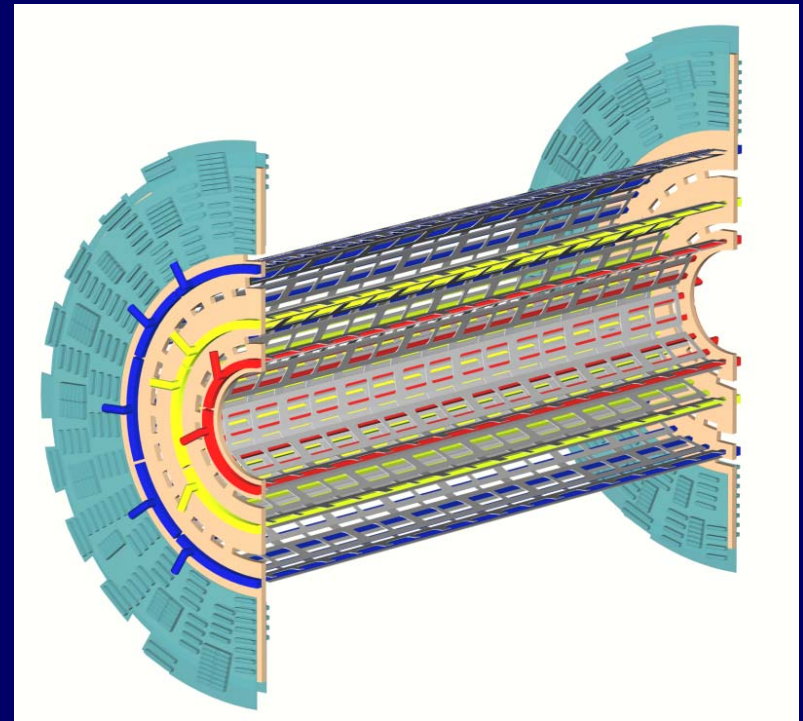
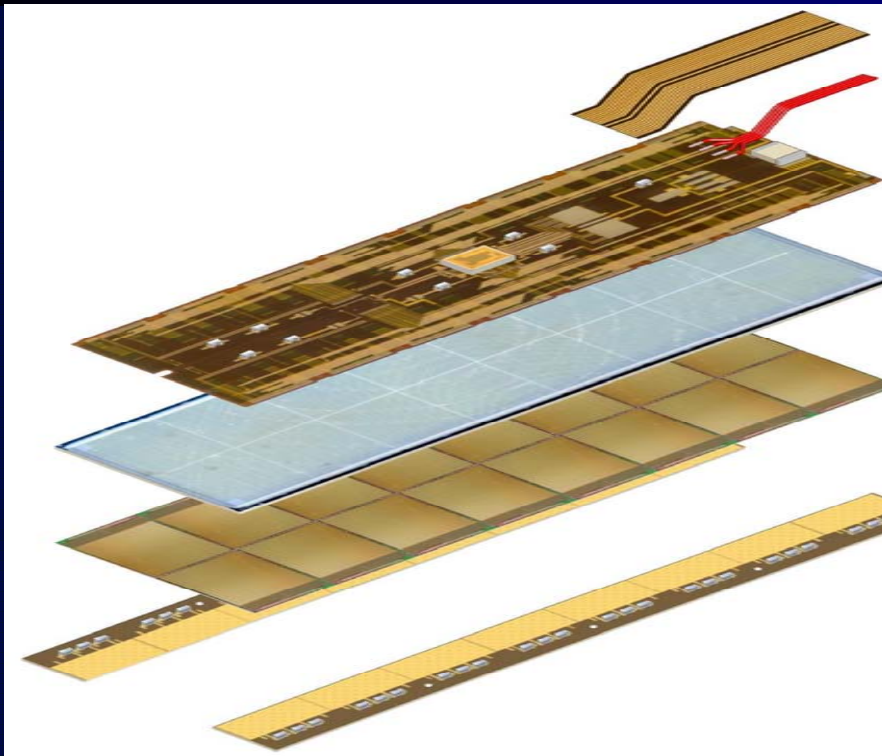

- Modules are constructed from sensors bump bonded to readout chip with power and data transfer via high density interconnects
- Cooling, power, and readout are fanned out at ends

Forward pixel construction

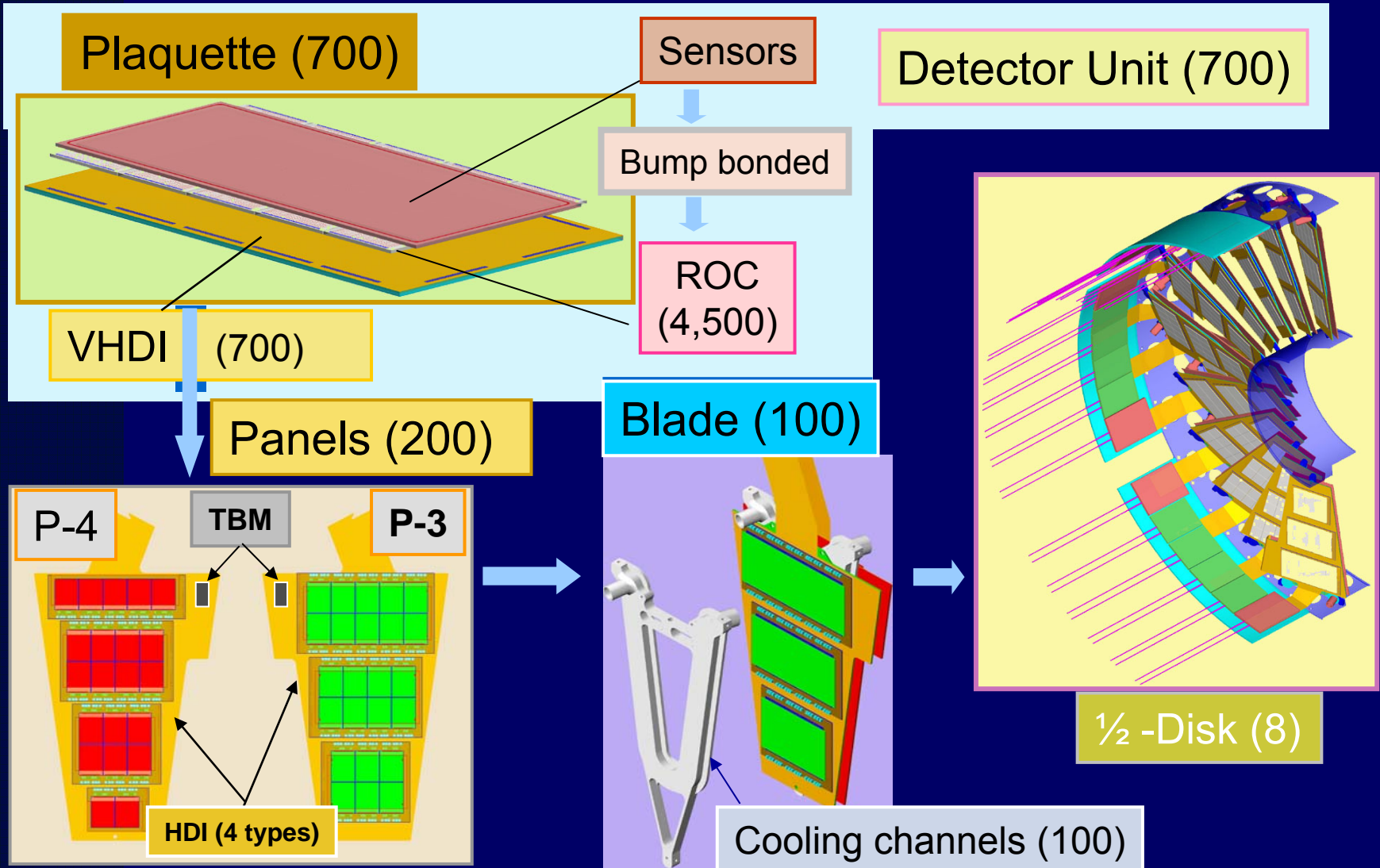

CMS Forward Pixels

2 of the 12 blades are populated in this prototype half disk



Panels mount on aluminum support and cooling channels

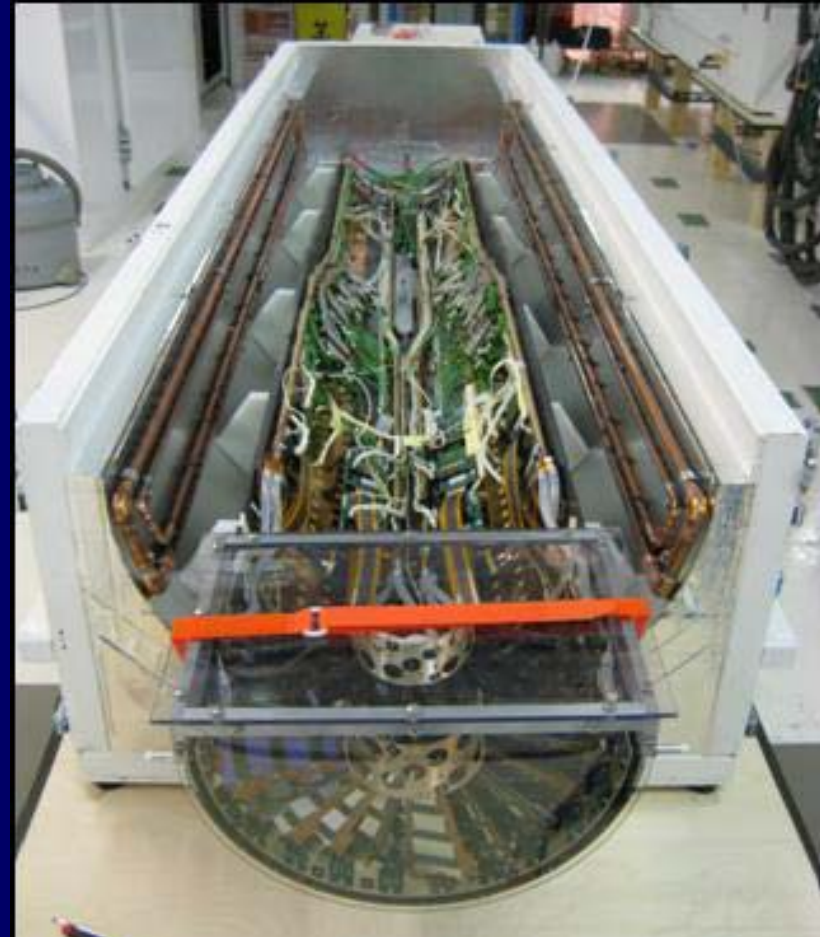

Half disks mounted in carbon fiber service cylinder which contains electronics and provides pathway for data, power, and cooling

CMS Silicon Strip Detectors

2300 square feet of silicon detectors

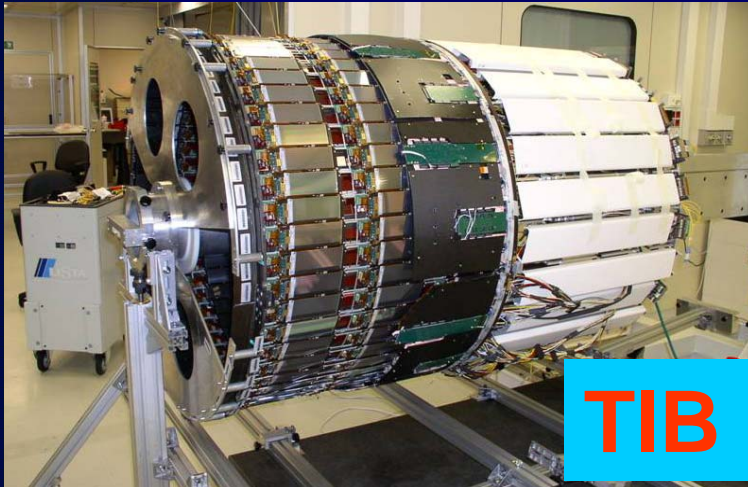

TIB



TEC



TOB

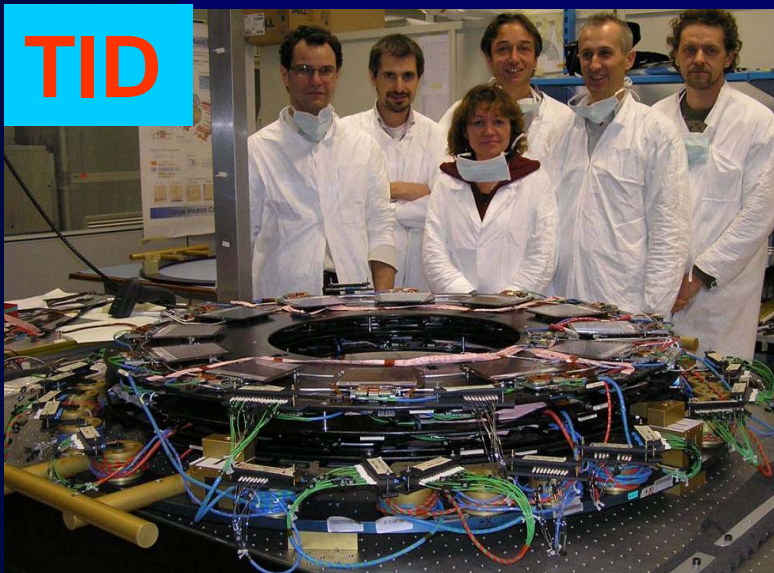

TID

11/7/07

Particle Physics at the Energy Frontier

30

Silicon detectors past and present

CMS: 4 tons and 75 million channels



CDF: <1 million channels

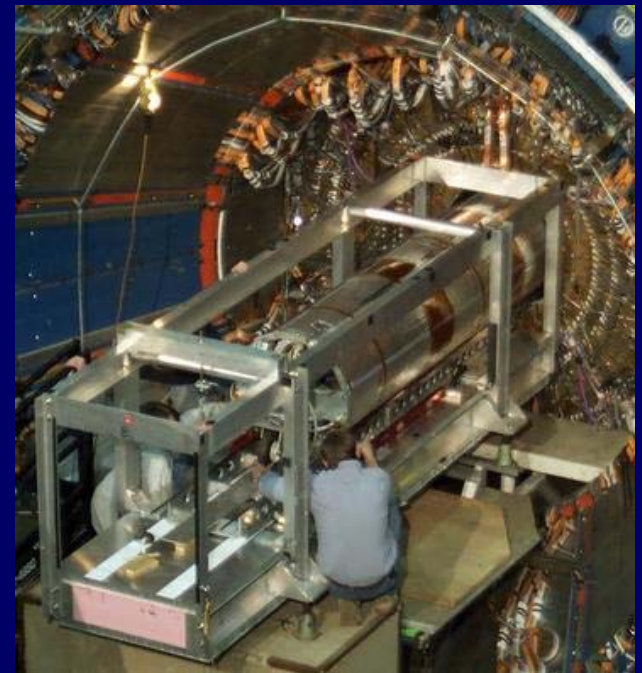

CMS Solenoid

- 4 T magnet at 4 K
- 6 m diameter and 12.5 m long (largest ever built)
- 220 t (including 6 t of NbTi)
- Stores 2.7 GJ — equivalent to 1300 lbs of TNT
- If magnet gets above superconducting temperature, energy is released as heat — need to plan for the worst
- Bends charged particles allowing tracker to measure momentum

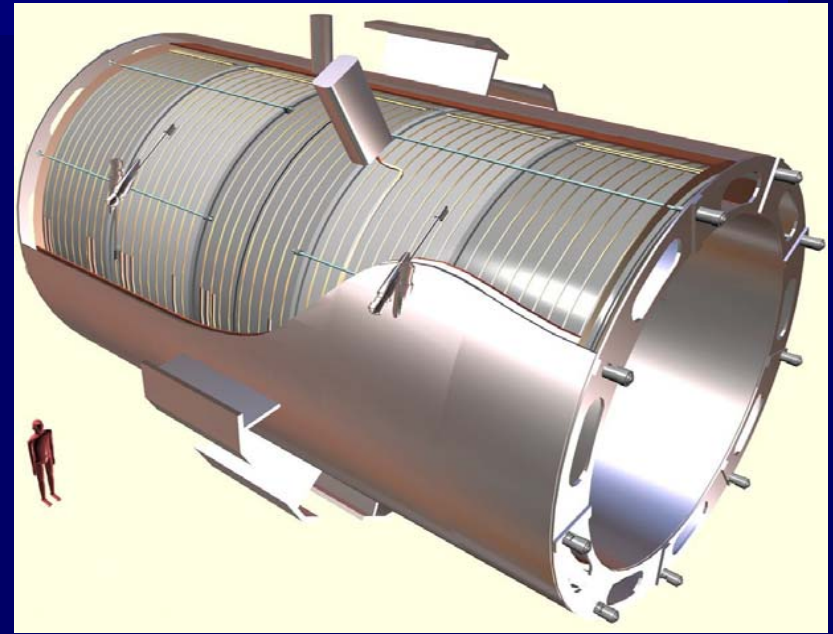

Calorimetry

- Particles shower in calorimeter creating other particles which shower and so on until no more energy is left
- The created charged particles release energy which can be collected and is proportional to the original particle energy

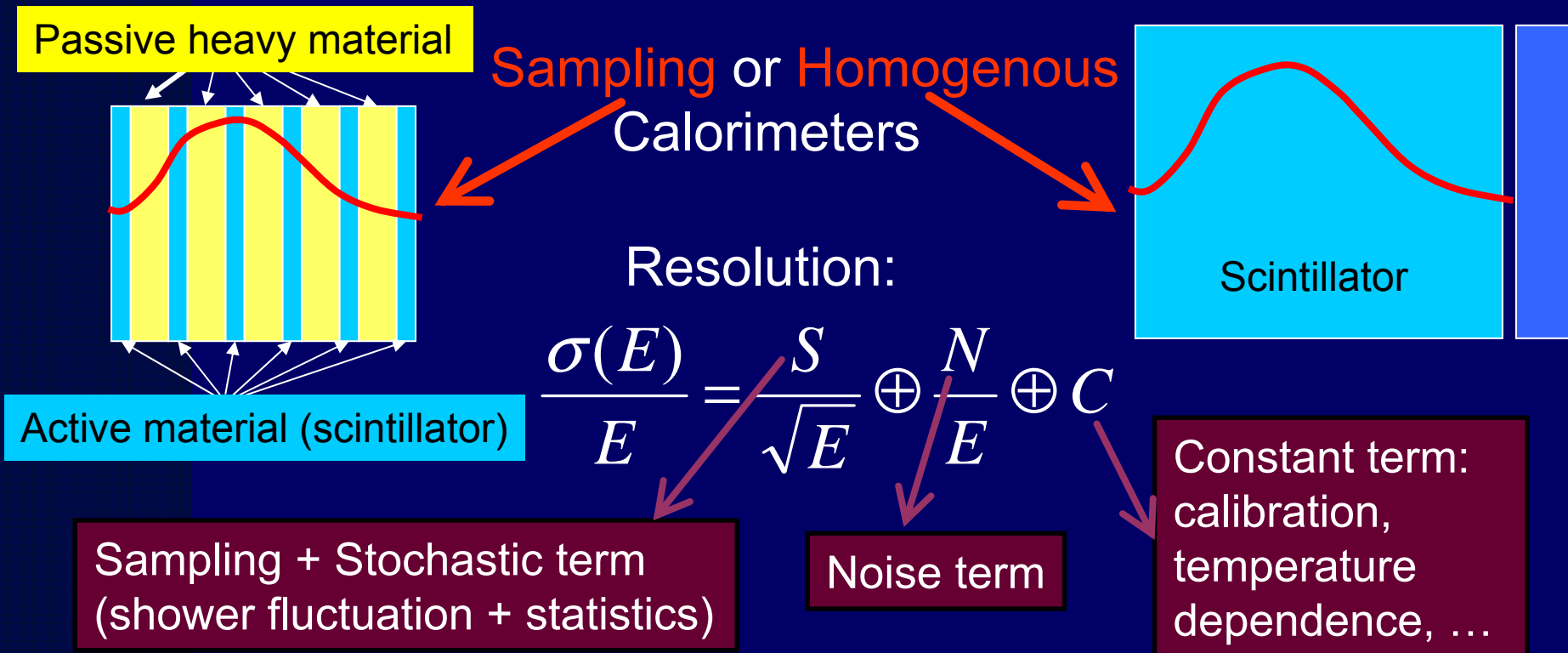

CMS ECAL

- Photons and electrons shower in high Z material
- Homogenous calorimeter
- Lead tungstate (PbWO_4) crystals: $2.3 \times 2.3 \times 23 \text{ cm}^3$
- Radiation hard, dense, and fast
- Low light yield & temperature sensitivity make it difficult
- Magnetic field and radiation require novel electronics APD and VPT

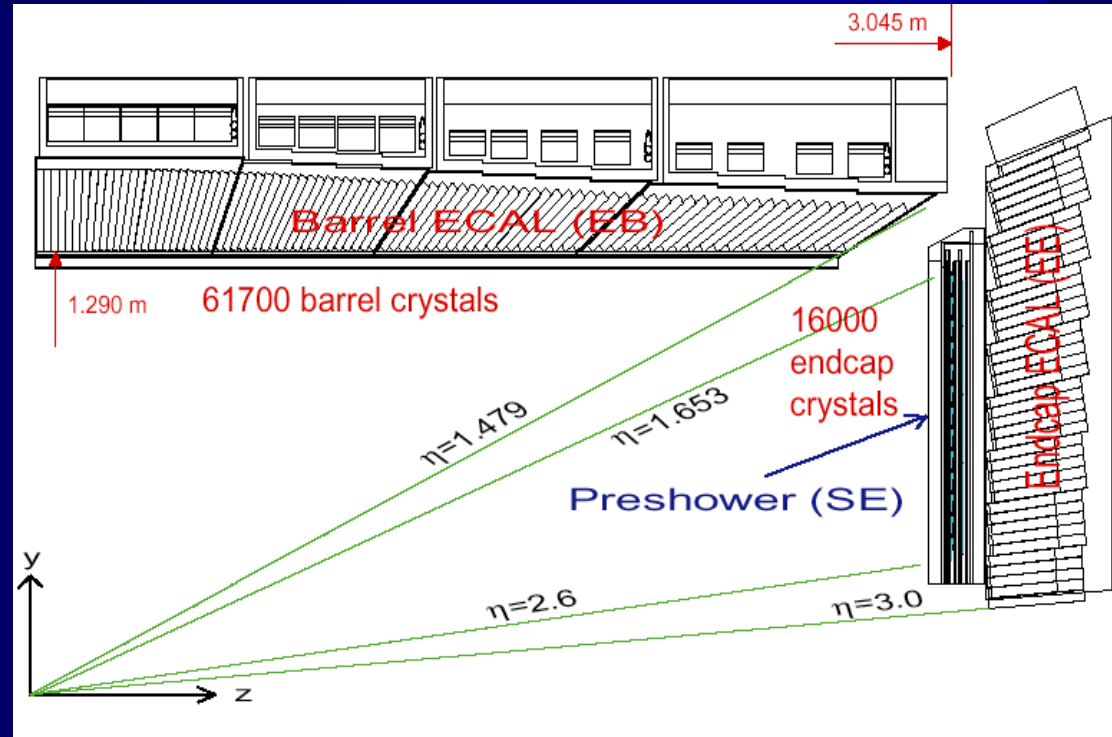

CMS HCAL

- Sampling calorimeter
- Brass absorber from Russian artillery shells (non-magnetic)
- Scintillating tiles with wavelength shifting (WLS) fiber
- WLS fiber is fed into a hybrid photo-diode (HPD) for light yield measurement

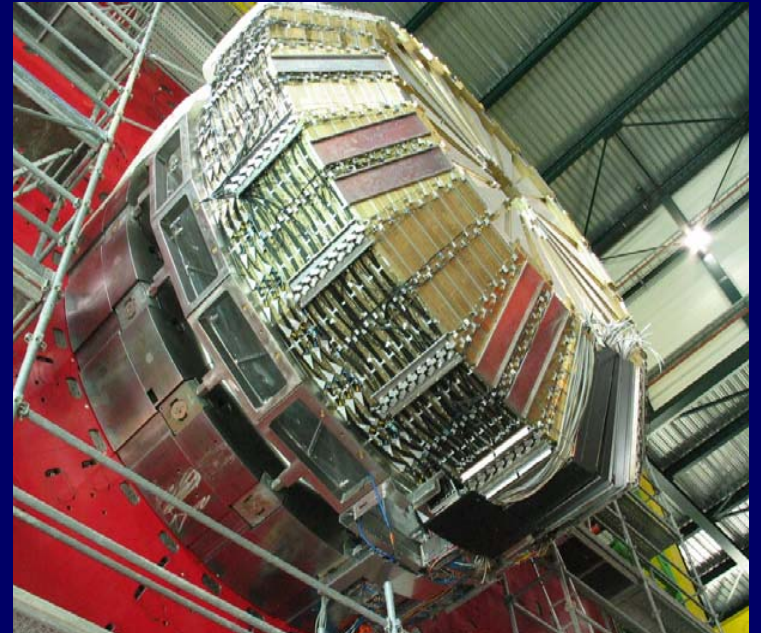
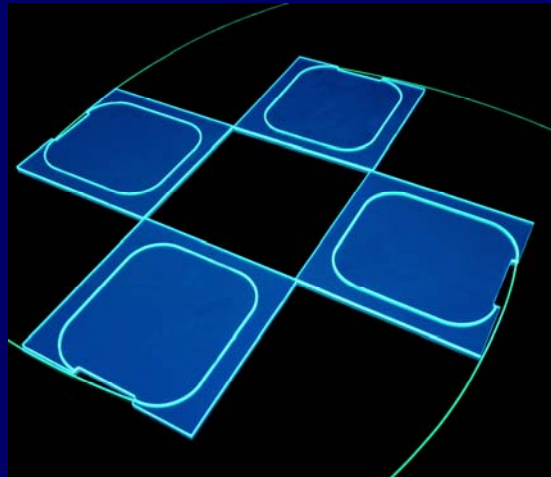

Muon systems

- Muons interact less than other charged particles
- Place detectors after material and what comes through is a muon
- Add B field & tracking to find momentum and link with main tracker
- 12000 t of iron is absorber and solenoid flux return
- Three tracking technologies: Drift Tube, Resistive Plate Chamber, & Cathode Strip Chamber

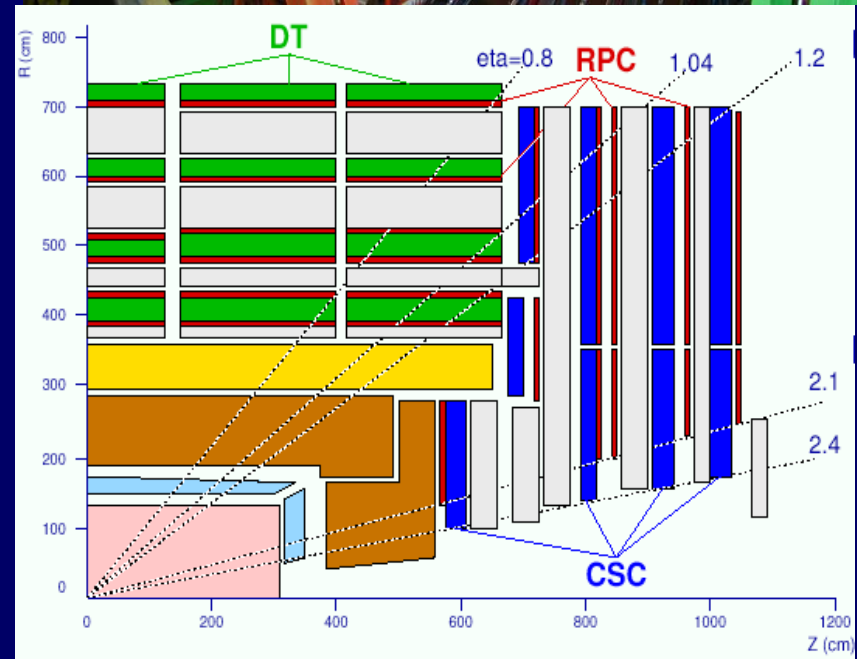
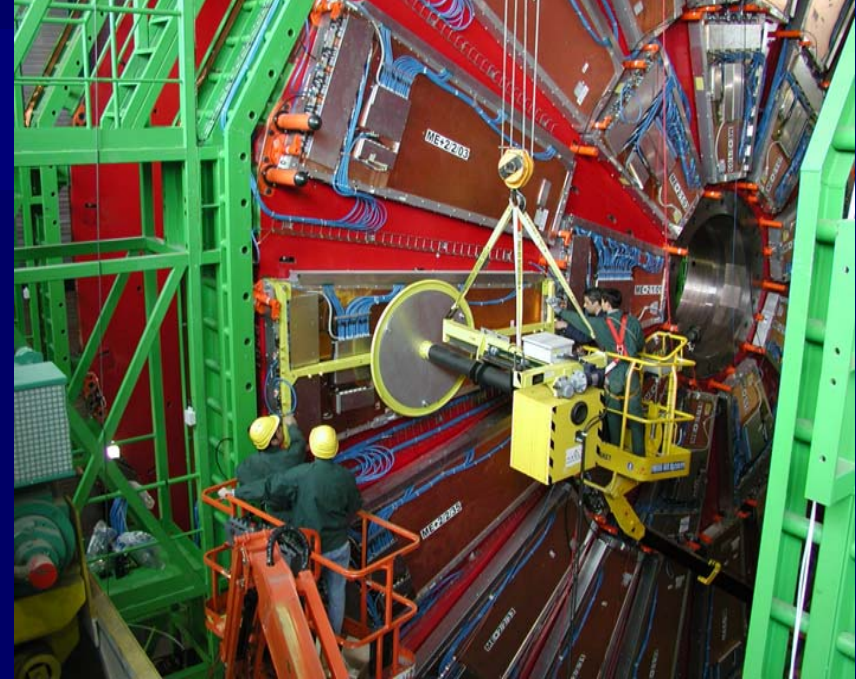

Picking signal out of background

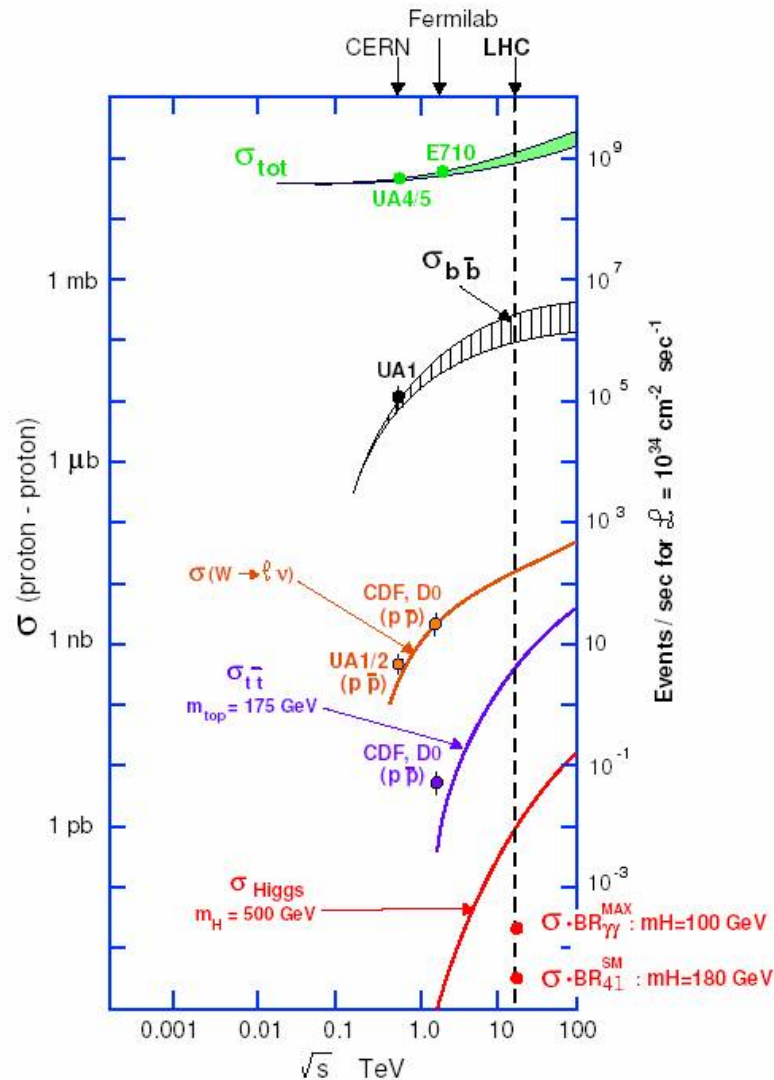

- Higgs cross section is 10^{-11} of the total cross section
- 99.9% of events are light QCD background: low energy hadrons
 - Reject by requiring high energy or leptons
- $b\bar{b}$ events are another large background but also come from interesting events
- W, Z, and top are backgrounds *and* signatures for good events

Triggering and data acquisition

The problem

- Beam crossings generate 1 MB of data from the experiment and occur at 40 MHz = 40 Terabytes/s
- Restricted to 100 Hz of events = 100 MB/s = 10 TB/day = 1 Petabyte per year
- Need to reject 99.9998% of events in quasi real time

The solution

- Hardware trigger finds jets, electrons, muons, and missing E_T and rejects 99.8% of events in $3 \mu\text{s}$
- Surviving 100 GB/s of events fed into ~ 1000 CPU farm where events are reconstructed and 0.1% kept

SM Higgs Decay Modes

Decay rate depends on (unknown) mass

Inclusive $H \rightarrow b\bar{b}$ not possible due to QCD background

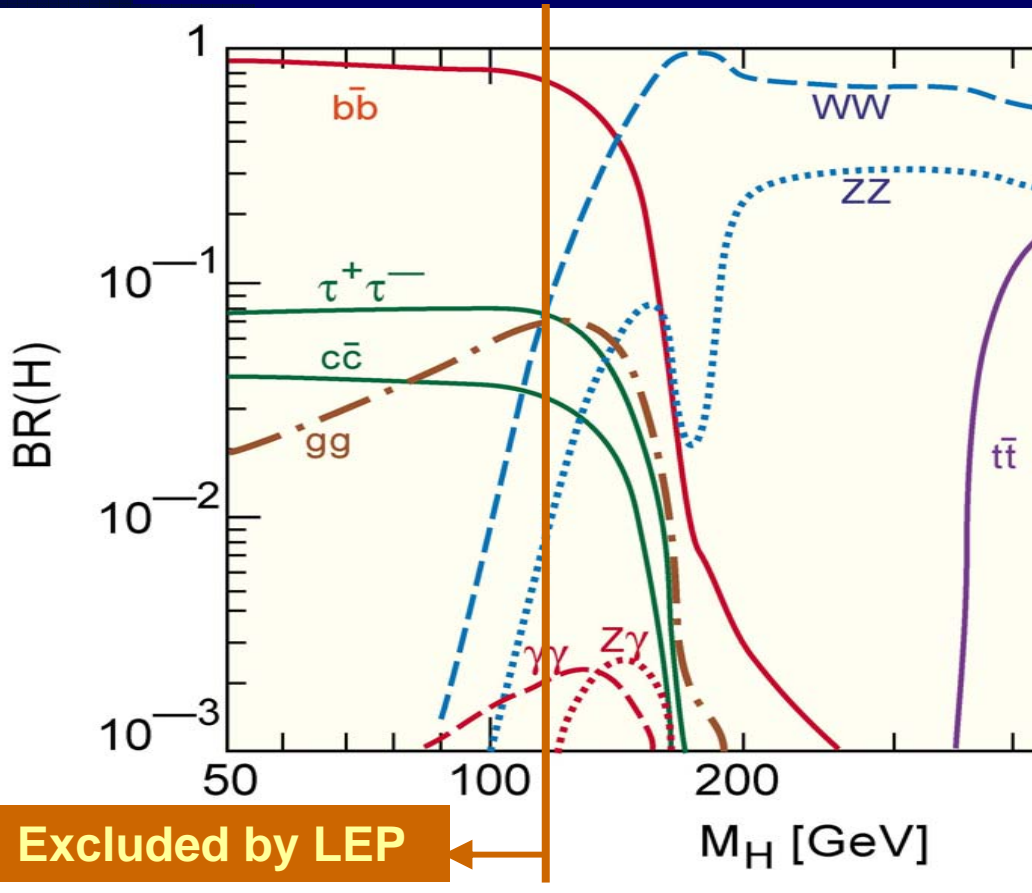

M_H range (GeV) Decay mode

$M_H < 130$	$H \rightarrow \gamma\gamma$
$130 < M_H < 150$	$H \rightarrow ZZ^*$
$150 < M_H < 180$	$H \rightarrow WW$
$180 < M_H < 600$	$H \rightarrow ZZ$

Higgs to 2 photons ($H \rightarrow \gamma\gamma$)

$H \rightarrow \gamma\gamma$ with $M_H = 120$ GeV as observed in the CMS detector

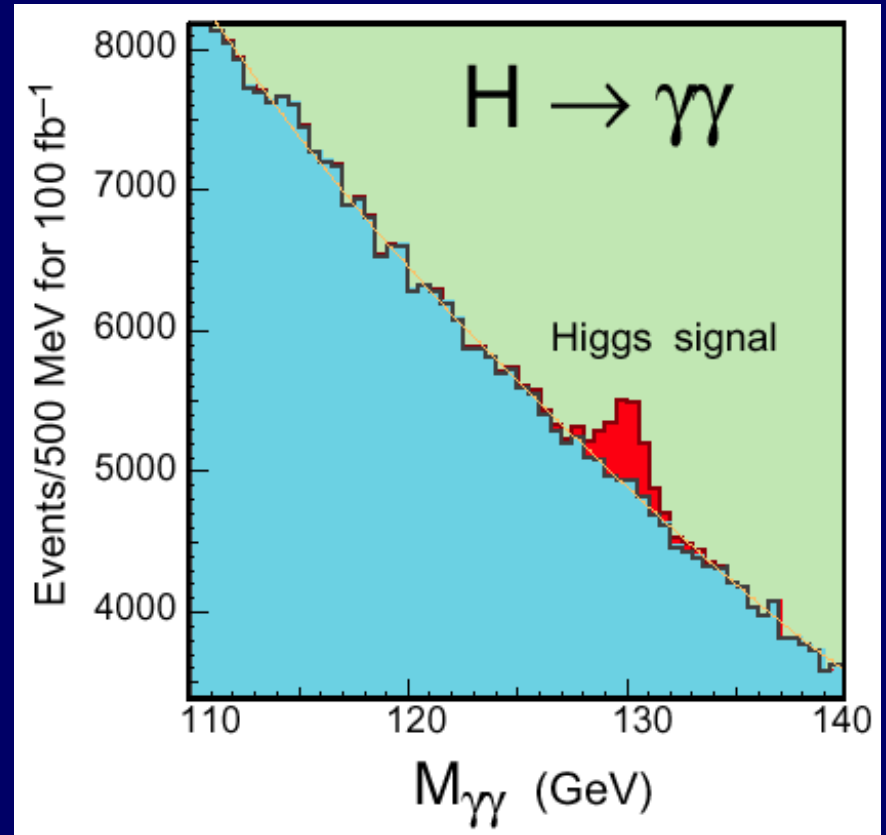
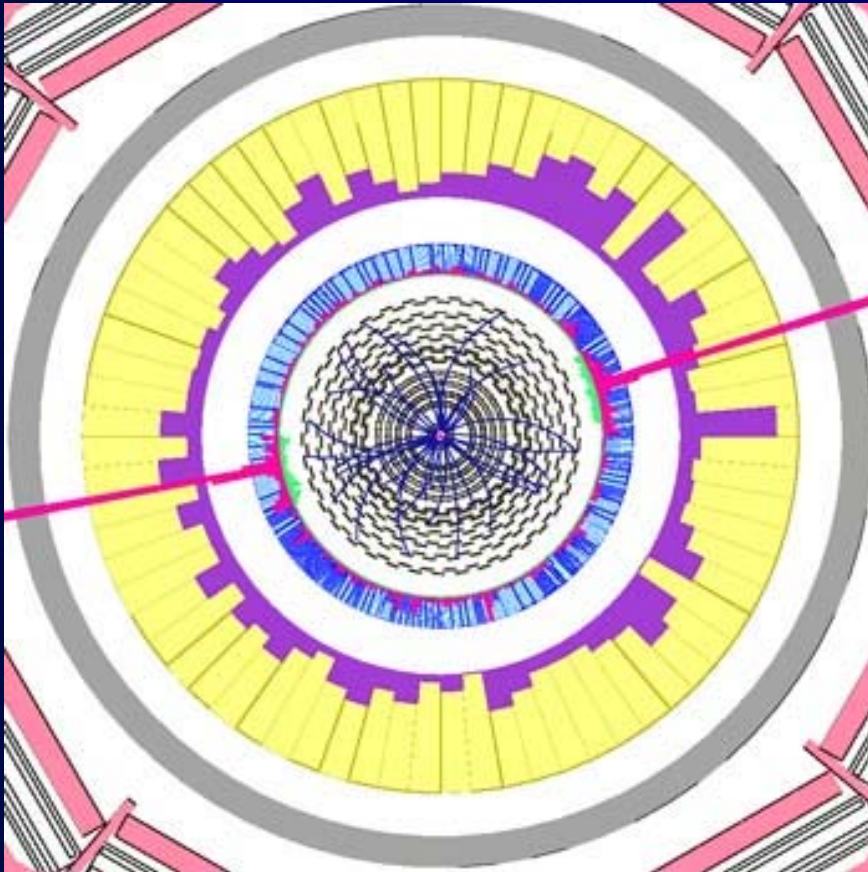

Excellent calorimeter provides 1 GeV mass resolution which allows a peak to be seen

Higgs reach to 1 TeV by 2010

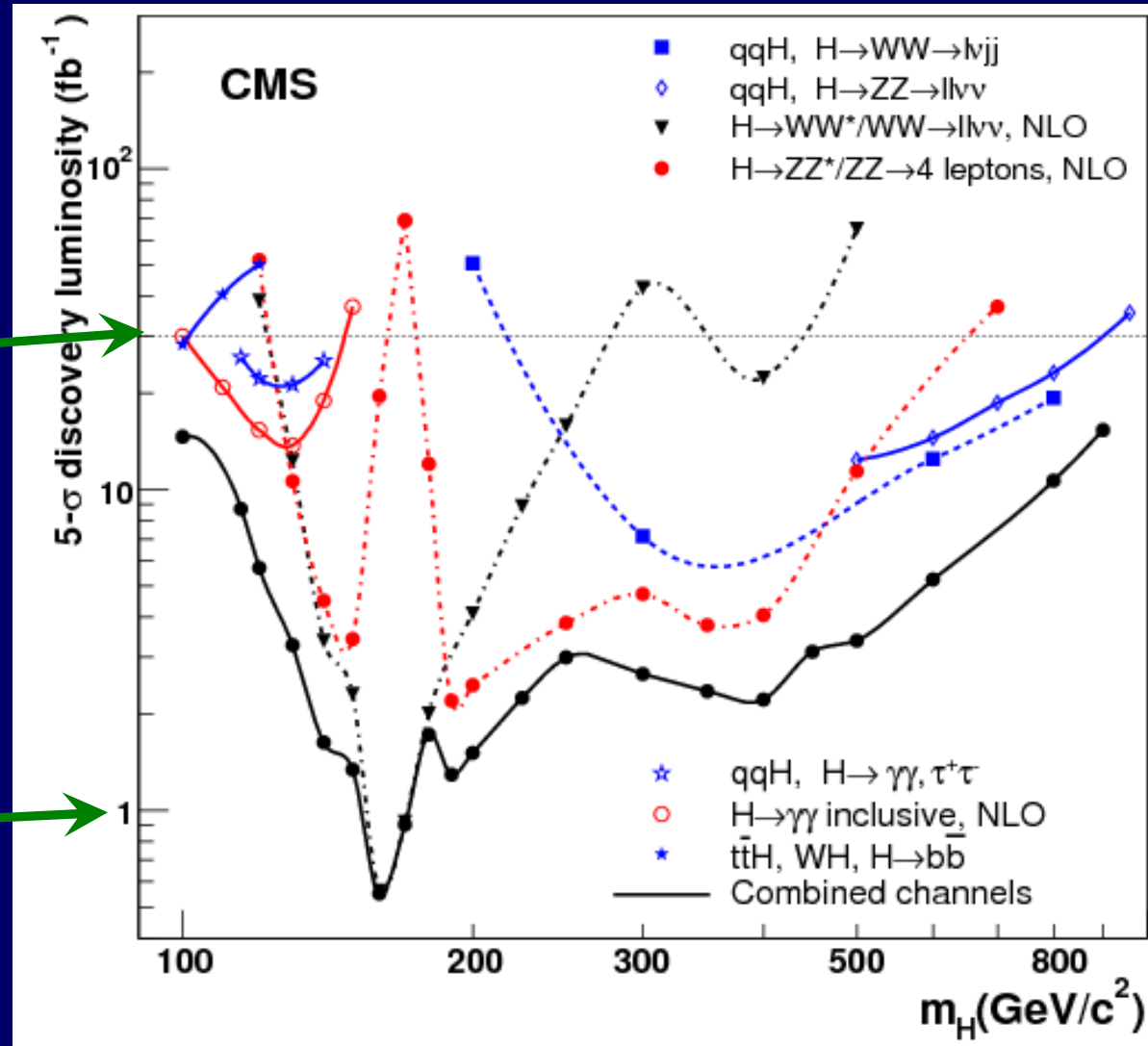

Should get to 20 fb^{-1} by 2010

Could get 1 fb^{-1} in 1st physics run (2008)

Searching for SUSY

- Even the 5 parameters of mSUGRA allow a huge range of variability (masses, branching rates, etc.)
- Expect to discover SUSY by finding an excess of some types of events like missing E_T or isolated leptons
- Determining exactly what kind of SUSY we have is the difficult part

Could find SUSY by 2008 with this kind of signature

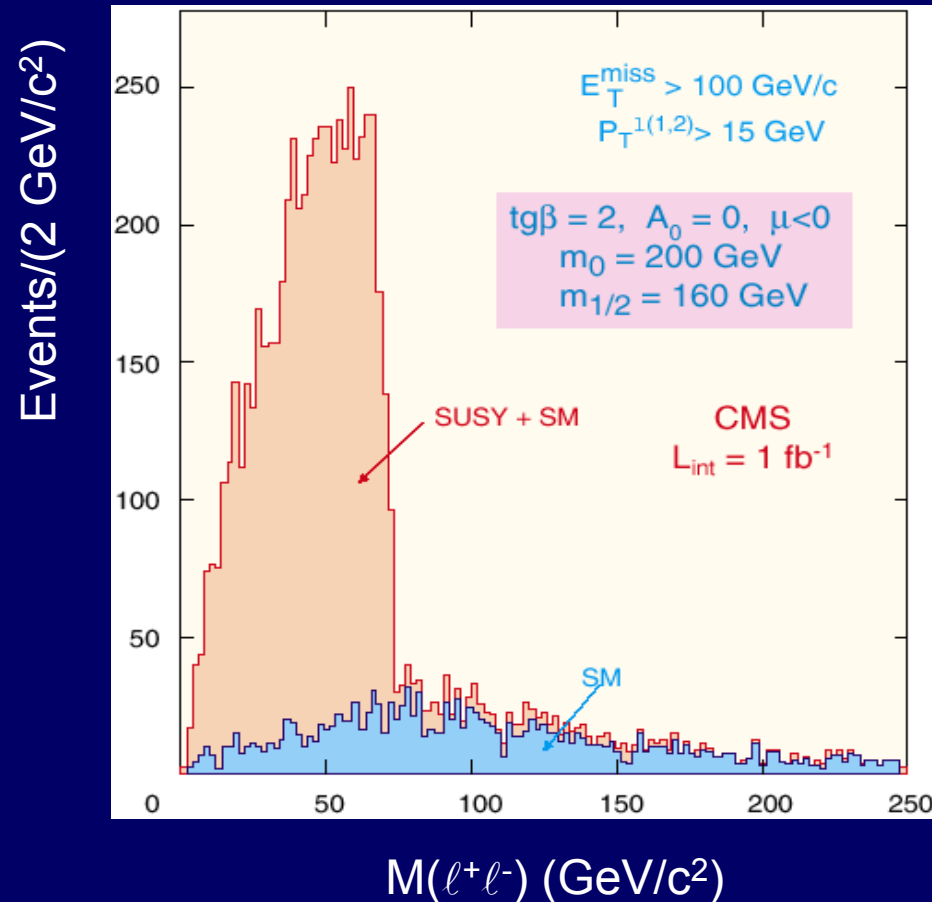

Near future of CMS

- Nearly everything is already in the cavern
- Integration and cabling is ongoing – very tricky
- Heavy lifting of muon endcaps completed by 12/21/07
- Tracker is installed by 12/21/07
- Cabling connections through January
- Installation and bakeout of beam pipe in January/February
- Pixel detectors inserted beginning of March
- Endcaps close up at the end of March

Near future timeline

- Detectors close up April, 2008
- LHC commissioning starts in May, 2008
- 14 TeV pp collisions to start July, 2008 and run until December
 - Could find SUSY
 - Could find high mass Z'
 - Can do lots of bread and butter physics: production, b-physics, ...
- 2009—2010: Medium luminosity with real chance to find Higgs and SUSY



Timeline of possible discoveries

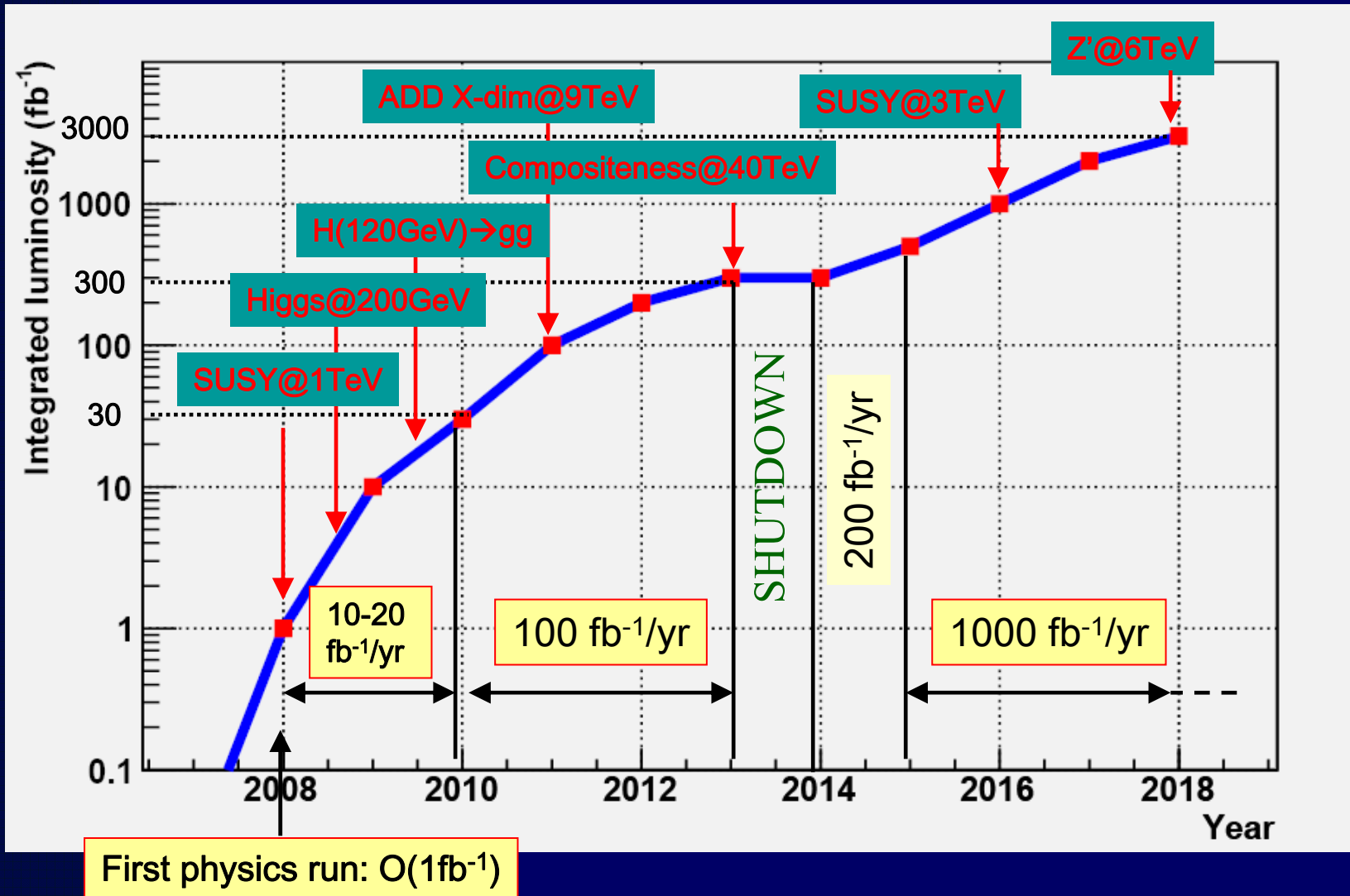

Summary

- We should find out what is responsible for electroweak symmetry breaking (Higgs?) which is the final piece of the Standard Model
- We will look for something around 1 TeV to take care of one hierarchy problem (SUSY?) which might also be the elusive dark matter
- Opening a new energy frontier can also bring lots of surprises, perhaps gravity related
- A year or two might see some of the answers coming out